

**Description**

CNR D/V/P/H series metal oxide varistor are nonlinear resistors, consisting main of zinc oxide and several kinds of metal oxide additive. They are bilateral and symmetrical V-I characteristics curve and unparalleled large peak current capability are used for absorption of transient voltage, suppression of pulse noise and circuit voltage stabilization.

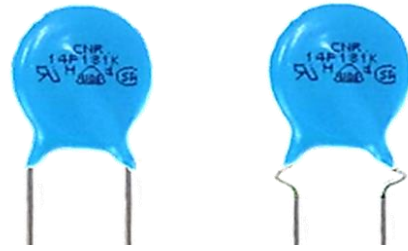





Agency Approvals			Features
Agency	Agency Approval	Certificate No.	1. RoHS compliant 2. Halogen-free series are available 3. Body size: $\varnothing 10 \sim \varnothing 20\text{mm}$ 4. CNR-10P431K~10P112K, CNR-14P201K~14P112K, CNR-18P201K~18P112K, CNR-20P201K~20P112K meet IEC 60950-1:2013 Annex Q requirement.
	UL 1449 4 <sup>th</sup> & cUL	VZCA2.E316325 VZCA8.E316325	
	IEC 61051-1	40037261 40044872	
	IEC 61051-2		
	IEC 61051-2-2		
	IEC 60950-1:2013 for 10 mm, 14mm, 18mm and 20mm only		
	CLASS 2213 31	1235900	
	GB/T 10193	CQC16001159204	<b>Applications</b> 1. Power supply 2. Home appliance 3. Industrial equipment 4. Telecommunication or telephone system 5. Smart meter 6. Lighting products 7. Photovoltaic industry
	GB/T 10194	CQC16001159206	
	GB 4943.1	CQC16001159163	
	GB 8898	CQC16001159197	

Max. Rating		
	P-Series	Units
AC Voltage Range (Vac)	11 to 680	V
DC Voltage Range(Vdc)	14 to 895	V
Peak Current for 8/20 $\mu$ S Current Wave	1500 to 15000	A
Energy Range For 10/1000 $\mu$ S Current Wave	4 to 720	J
Operation Ambient Temperature Range	-40 to +105	$^{\circ}\text{C}$
Storage Temperature Range	-40 to +125	$^{\circ}\text{C}$
Varistor Voltage Range Vn(Vdc)	18 to 1100	V
Insulation Resistance	>1000	M $\Omega$
Typical Response Time	<25	ns





Device Ratings and Characteristics														
Part No.	Device Marking	Maximum Allowable Voltage		Varistor Voltage (@1mA)			Clamping Voltage @ Test Current (@8/20µs)		Maximum Energy (@10/1000µs)	Maximum Peak Current (@8/20µs)	Rated Power	Typical Capacitance (@1KHz)	UL 1449 4th ,In @8/20us	Related Standards Symbol
		ACrms(V)	DC(V)	Vn(Vdc)	Min.	Max.	Vc(V)	Ip(A)	(J)	(A)	(W)	(pF)	(KA)	
CNR-10P180K	10P180K	11	14	18	16	20	36	5	4	1500	0.08	8000	1	⊙
CNR-10P220K	10P220K	14	18	22	20	24	43	5	5	1500	0.08	7000		⊙
CNR-10P270K	10P270K	17	22	27	24	30	53	5	6	1500	0.08	5500		⊙
CNR-10P330K	10P330K	20	26	33	30	36	65	5	7.5	1500	0.08	4100		⊙
CNR-10P390K	10P390K	25	31	39	35	43	77	5	8.6	1500	0.08	3900		⊙
CNR-10P470K	10P470K	30	38	47	42	52	93	5	10	1500	0.08	3300		⊙
CNR-10P560K	10P560K	35	45	56	50	62	110	5	11	1500	0.08	2800		⊙
CNR-10P680K	10P680K	40	56	68	61	75	135	5	14	1500	0.08	2300		⊙
CNR-10P201K	10P201K	130	170	200	180	220	340	25	52	4000	0.4	625	2	△
CNR-10P221K	10P221K	140	180	220	198	242	360	25	58	4000	0.4	570		△
CNR-10P241K	10P241K	150	200	240	216	264	395	25	64	4000	0.4	525		△
CNR-10P271K	10P271K	175	225	270	243	297	455	25	67	4000	0.4	470		△
CNR-10P301K	10P301K	195	250	300	270	330	500	25	70	4000	0.4	415		△
CNR-10P331K	10P331K	215	275	330	297	363	550	25	72	4000	0.4	350		△
CNR-10P361K	10P361K	230	300	360	324	396	595	25	76	4000	0.4	350		△
CNR-10P391K	10P391K	250	320	390	351	429	650	25	82	4000	0.4	325		△
CNR-10P431K	10P431K	275	350	430	387	473	710	25	93	4000	0.4	290		△
CNR-10P471K	10P471K	300	385	470	423	517	775	25	99	4000	0.4	260		△
CNR-10P511K	10P511K	320	410	510	459	561	845	25	107	4000	0.4	240		△
CNR-10P561K	10P561K	350	460	560	504	616	915	25	113	4000	0.4	220		△
CNR-10P621K	10P621K	395	510	620	558	682	1020	25	125	4000	0.4	200		△
CNR-10P681K	10P681K	420	560	680	612	748	1120	25	128	4000	0.4	190		△
CNR-10P751K	10P751K	465	615	750	675	825	1235	25	134	4000	0.4	175		△
CNR-10P781K	10P781K	485	640	780	702	858	1290	25	140	4000	0.4	170		△
CNR-10P821K	10P821K	510	670	820	738	902	1355	25	146	4000	0.4	160		△
CNR-10P911K	10P911K	550	745	910	819	1001	1500	25	152	4000	0.4	140		△
CNR-10P102K	10P102K	625	825	1000	900	1100	1650	25	170	4000	0.4	132		△
CNR-10P112K	10P112K	680	895	1100	990	1210	1815	25	180	4000	0.4	120		△

**Related Standards**

Symbols	⊙	△
Approval	    	

Device Ratings and Characteristics														
Part No.	Device Marking	Maximum Allowable Voltage		Varistor Voltage (@1mA)			Clamping Voltage @ Test Current (@8/20µs)		Maximum Energy (@10/1000µs)	Maximum Peak Current (@8/20µs)	Rated Power	Typical Capacitance (@1KHz)	UL 1449 4th ,In @8/20us	Related Standards Symbol
		ACrms(V)	DC(V)	Vn(Vdc)	Min.	Max.	Vc(V)	Ip(A)	(J)	(A)	(W)	(pF)	(KA)	
CNR-14P180K	14P180K	11	14	18	16	20	36	10	11	3000	0.15	18500	2	⊙
CNR-14P220K	14P220K	14	18	22	20	24	43	10	14	3000	0.15	16400		⊙
CNR-14P270K	14P270K	17	22	27	24	30	53	10	18	3000	0.15	13000		⊙
CNR-14P330K	14P330K	20	26	33	30	36	65	10	23	3000	0.15	9500		⊙
CNR-14P390K	14P390K	25	31	39	35	43	77	10	26	3000	0.15	8800		⊙
CNR-14P470K	14P470K	30	38	47	42	52	93	10	33	3000	0.15	7700		⊙
CNR-14P560K	14P560K	35	45	56	50	62	110	10	41	3000	0.15	6400		⊙
CNR-14P680K	14P680K	40	56	68	61	75	135	10	46	3000	0.15	5600		⊙
CNR-14P201K	14P201K	130	170	200	180	220	340	50	96	8000	0.6	770	3	△
CNR-14P221K	14P221K	140	180	220	198	242	360	50	104	8000	0.6	740		△
CNR-14P241K	14P241K	150	200	240	216	264	395	50	112	8000	0.6	700		△
CNR-14P271K	14P271K	175	225	270	243	297	455	50	120	8000	0.6	640		△
CNR-14P301K	14P301K	195	250	300	270	330	500	50	136	8000	0.6	600		△
CNR-14P331K	14P331K	215	275	330	297	363	550	50	152	8000	0.6	580		△
CNR-14P361K	14P361K	230	300	360	324	396	595	50	164	8000	0.6	540		△
CNR-14P391K	14P391K	250	320	390	351	429	650	50	176	8000	0.6	500		△
CNR-14P431K	14P431K	275	350	430	387	473	710	50	200	8000	0.6	450		△
CNR-14P471K	14P471K	300	385	470	423	517	775	50	220	8000	0.6	400		△
CNR-14P511K	14P511K	320	410	510	459	561	845	50	240	8000	0.6	350		△
CNR-14P561K	14P561K	350	460	560	504	616	915	50	240	8000	0.6	350		△
CNR-14P621K	14P621K	395	510	620	558	682	1020	50	250	8000	0.6	330		△
CNR-14P681K	14P681K	420	560	680	612	748	1120	50	260	8000	0.6	320		△
CNR-14P751K	14P751K	465	615	750	675	825	1235	50	270	8000	0.6	300		△
CNR-14P781K	14P781K	485	640	780	702	858	1290	50	275	8000	0.6	300		△
CNR-14P821K	14P821K	510	670	820	738	902	1355	50	280	8000	0.6	270		△
CNR-14P911K	14P911K	550	745	910	819	1001	1500	50	295	8000	0.6	260		△
CNR-14P102K	14P102K	625	825	1000	900	1100	1650	50	335	8000	0.6	250		△
CNR-14P112K	14P112K	680	895	1100	990	1210	1815	50	360	8000	0.6	240		△

**Related Standards**

Symbols	⊙		△		
Approval					





Device Ratings and Characteristics														
Part No.	Device Marking	Maximum Allowable Voltage		Varistor Voltage (@1mA)			Clamping Voltage @ Test Current (@8/20µs)		Maximum Energy (@10/1000µs)	Maximum Peak Current (@8/20µs)	Rated Power	Typical Capacitance (@1KHz)	UL 1449 4th ,In @8/20us	Related Standards Symbol
		ACrms(V)	DC(V)	Vn(Vdc)	Min.	Max.	Vc(V)	Ip(A)	(J)	(A)	(W)	(pF)	(KA)	
CNR-18P180K	18P180K	11	14	18	16	20	36	20	20	4500	0.3	42000	3	○
CNR-18P220K	18P220K	14	18	22	20	24	43	20	26	4500	0.3	37000		○
CNR-18P270K	18P270K	17	22	27	24	30	53	20	31	4500	0.3	29200		○
CNR-18P330K	18P330K	20	26	33	30	36	65	20	39	4500	0.3	21400		○
CNR-18P390K	18P390K	25	31	39	35	43	77	20	44	4500	0.3	19800		○
CNR-18P470K	18P470K	30	38	47	42	52	93	20	52	4500	0.3	17300		○
CNR-18P560K	18P560K	35	45	56	50	62	110	20	57	4500	0.3	14400		○
CNR-18P680K	18P680K	40	56	68	61	75	135	20	72	4500	0.3	12600		○
CNR-18P201K	18P201K	130	170	200	180	220	340	75	175	12000	1	1700	5	△
CNR-18P221K	18P221K	140	180	220	198	242	360	75	185	12000	1	1600		△
CNR-18P241K	18P241K	150	200	240	216	264	395	75	198	12000	1	1500		△
CNR-18P271K	18P271K	175	225	270	243	297	455	75	220	12000	1	1300		△
CNR-18P301K	18P301K	195	250	300	270	330	500	75	245	12000	1	1200		△
CNR-18P331K	18P331K	215	275	330	297	363	550	75	268	12000	1	1100		△
CNR-18P361K	18P361K	230	300	360	324	396	595	75	315	12000	1	1100		△
CNR-18P391K	18P391K	250	320	390	351	429	650	75	350	12000	1	1100		△
CNR-18P431K	18P431K	275	350	430	387	473	710	75	380	12000	1	1000		△
CNR-18P471K	18P471K	300	385	470	423	517	775	75	405	12000	1	900		△
CNR-18P511K	18P511K	320	410	510	459	561	845	75	445	12000	1	800		△
CNR-18P561K	18P561K	350	460	560	504	616	915	75	475	12000	1	750		△
CNR-18P621K	18P621K	395	510	620	558	682	1020	75	490	12000	1	570		△
CNR-18P681K	18P681K	420	560	680	612	748	1120	75	500	12000	1	550		△
CNR-18P751K	18P751K	465	615	750	675	825	1235	75	525	12000	1	530		△
CNR-18P781K	18P781K	485	640	780	702	858	1290	75	535	12000	1	500		△
CNR-18P821K	18P821K	510	670	820	738	902	1355	75	545	12000	1	500		△
CNR-18P911K	18P911K	550	745	910	819	1001	1500	75	595	12000	1	480		△
CNR-18P102K	18P102K	625	825	1000	900	1100	1650	75	650	12000	1	460		△
CNR-18P112K	18P112K	680	895	1100	990	1210	1815	75	720	12000	1	400		△

**Related Standards**

Symbols	○	△		
Approval				

Device Ratings and Characteristics														
Part No.	Device Marking	Maximum Allowable Voltage		Varistor Voltage (@1mA)			Clamping Voltage @ Test Current (@8/20µs)		Maximum Energy (@10/1000µs)	Maximum Peak Current (@8/20µs)	Rated Power	Typical Capacitance (@1KHz)	UL 1449 4th ,In @8/20us	Related Standards Symbol
		ACrms(V)	DC(V)	Vn(Vdc)	Min.	Max.	Vc(V)	Ip(A)	(J)	(A)	(W)	(pF)	(KA)	
CNR-20P180K	20P180K	11	14	18	16	20	36	20	20	6000	0.3	42000	3	⊙
CNR-20P220K	20P220K	14	18	22	20	24	43	20	26	6000	0.3	37000		⊙
CNR-20P270K	20P270K	17	22	27	24	30	53	20	31	6000	0.3	29200		⊙
CNR-20P330K	20P330K	20	26	33	30	36	65	20	39	6000	0.3	21400		⊙
CNR-20P390K	20P390K	25	31	39	35	43	77	20	44	6000	0.3	19800		⊙
CNR-20P470K	20P470K	30	38	47	42	52	93	20	52	6000	0.3	17300		⊙
CNR-20P560K	20P560K	35	45	56	50	62	110	20	57	6000	0.3	14400		⊙
CNR-20P680K	20P680K	40	56	68	61	75	135	20	72	6000	0.3	12600		⊙
CNR-20P201K	20P201K	130	170	200	180	220	340	100	175	15000	1	1700	5	△
CNR-20P221K	20P221K	140	180	220	198	242	360	100	185	15000	1	1600		△
CNR-20P241K	20P241K	150	200	240	216	264	395	100	198	15000	1	1500		△
CNR-20P271K	20P271K	175	225	270	243	297	455	100	220	15000	1	1300		△
CNR-20P301K	20P301K	195	250	300	270	330	500	100	245	15000	1	1200		△
CNR-20P331K	20P331K	215	275	330	297	363	550	100	268	15000	1	1100		△
CNR-20P361K	20P361K	230	300	360	324	396	595	100	315	15000	1	1100		△
CNR-20P391K	20P391K	250	320	390	351	429	650	100	350	15000	1	1100		△
CNR-20P431K	20P431K	275	350	430	387	473	710	100	380	15000	1	1000		△
CNR-20P471K	20P471K	300	385	470	423	517	775	100	405	15000	1	900		△
CNR-20P511K	20P511K	320	410	510	459	561	845	100	445	15000	1	800		△
CNR-20P561K	20P561K	350	460	560	504	616	915	100	475	15000	1	750		△
CNR-20P621K	20P621K	395	510	620	558	682	1020	100	490	15000	1	570		△
CNR-20P681K	20P681K	420	560	680	612	748	1120	100	500	15000	1	550		△
CNR-20P751K	20P751K	465	615	750	675	825	1235	100	525	15000	1	530		△
CNR-20P781K	20P781K	485	640	780	702	858	1290	100	535	15000	1	500		△
CNR-20P821K	20P821K	510	670	820	738	902	1355	100	545	15000	1	500		△
CNR-20P911K	20P911K	550	745	910	819	1001	1500	100	595	15000	1	480		△
CNR-20P102K	20P102K	625	825	1000	900	1100	1650	100	650	15000	1	460		△
CNR-20P112K	20P112K	680	895	1100	990	1210	1815	100	720	15000	1	400		△

**Related Standards**

Symbols	⊙		△		
Approval					

**Reliability (Test items comply with customer request)**

Item	Standard	Test Conditions / Methods	Specifications
Robustness of terminations	IEC 60068-2-21 Test Ua1	F = 10 N (d ≤ 0.8 mm), F = 20 N (d = 1 mm)	$\Delta V_{1mA}/V_{1mA} \leq \pm 10\%$ No visible damage
Solderability	IEC 60068-2-20 Test Ta (Method 1)	T = 235±5°C, d = 2±0.5s	Approximately ≥ 95%
Resistance to soldering heat	IEC 60068-2-20 Test Tb (Method 1A)	T = 260±5°C, d = 10±1s	$\Delta V_{1mA}/V_{1mA} \leq \pm 5\%$ No visible damage
Shock	IEC 60068-2-27 Test Ea	Pulse shape: half-sine. a = 490 m/s <sup>2</sup> , d = 11ms. N = 6 x 3 shocks	$\Delta V_{1mA}/V_{1mA} \leq \pm 5\%$ No visible damage
Vibration	IEC 60068-2-6 Test Fc (Method B4)	Frequency range: 10 Hz to 55 Hz, a = 0.75 mm or 98 m/s <sup>2</sup> (whichever is the less), d = 3x2 h	$\Delta V_{1mA}/V_{1mA} \leq \pm 5\%$ No visible damage
Needle flame test	IEC 60695-11-5	Severity: Vertical 10 s	Duration of burning: 5 s max.
Voltage under pulse condition	IEC 61051-2	At class current, 8/20µs	As specified in specification
Voltage proof	IEC 61051-2	Metal balls method (4.8.1.2) 2500 V, 60 s	No breakdown or flashover
Pulse current - 8/20 µs	IEC 61051-2	8/20 µs, 10 times, I peak=0.25*Imax	$\Delta V/V \leq \pm 10\%$ No visible damage
Pulse current - 10/1000 µs	IEC 61051-2	10/1000 µs, 10 times, Ipeak = 0.0075* Imax	$\Delta V_{1mA}/V_{1mA} \leq \pm 10\%$ No visible damage
Combination pulse	IEC 60950-1:2013 Annex Q	Additional test: 10 pulses (combination pulse 6KV/3KA), in one direction, 1 per min	$\Delta V_{1mA}/V_{1mA} \leq \pm 10\%$ No visible damage U ≤ 1.1 U <sub>initial</sub> Voltage proof : No breakdown or flashover
Rapid change of temperature	IEC 60068-2-14 Test Na	N = 5 cycles, d = 30 min, θA = -40±3°C, θB = 85±2°C	$\Delta V_{1mA}/V_{1mA} \leq \pm 10\%$ No visible damage
Climatic sequence	IEC 60068-2-2 Test Ba IEC 60068-2-30 Test Db IEC 60068-2-1 Test Aa IEC 60068-2-30 Test Db	Dry heat, Test Ba:16±2h, T = 85±2°C Damp heat, Test Db first cycle :24h, T = 55±2°C Cold, Test Aa :2h, T = -40±3°C Damp heat Test Ba remaining cycles:5 cycle	$\Delta V_{1mA}/V_{1mA} \leq \pm 10\%$ No visible damage R <sub>ISO</sub> ≥ 100MΩ Voltage proof:No breakdown or flashover
Endurance at upper category temperature	IEC 61051-1 (4.21)	T:max temperature as specified, Duration: 1000 h, Voltage: max. a.c. voltage	$\Delta V/V \leq \pm 10\%$ No visible damage R <sub>ISO</sub> ≥ 1000MΩ U ≤ 1,1 U <sub>initial</sub>

**Reliability**

Item	Standard	Test Conditions / Methods	Specifications
Damp heat (Steady state)	IEC 60068-2-78 Test Ca	T = 40±2°C, RH = 93(+2/-3)%, 56d , 4 specimens:No voltage applied , Other 4 specimens:Applied voltage: 10% of the max. d.c. voltage	$\Delta V_{I_{max}}/V_{I_{max}} \leq \pm 10\%$ $R_{ISO} \geq 100M\Omega$
Maximum Peak Current	Specification Standard	I <sub>max</sub> , 8/20 μs, 1 time	$\Delta V_{I_{max}}/V_{I_{max}} \leq \pm 10\%$ No visible damage
Nominal Discharge Current Test	UL1449 4th	I <sub>n</sub> , 8/20 μs, 15 times, Interval 60s.	$\Delta V/V \leq \pm 10\%$ No visible damage
Varistor Voltage Temp. Coefficient	Specification Standard	$\frac{V_{I_{mA}} \text{ at } 85^{\circ}\text{C} - V_{I_{mA}} \text{ at } 25^{\circ}\text{C}}{V_{I_{mA}} \text{ at } 25^{\circ}\text{C}} \times \frac{1}{60} \times 100(\%/^{\circ}\text{C})$	-0.05 ≤ TC ≤ 0.05(%/°C)
High Temperature Storage	IEC60068-2-2	1000h, T = 125±2°C	$\Delta V/V \leq \pm 5\%$ No visible damage
Max. Energy	Specification Standard	10/1000 μs, 1 time, Max. Energy	$\Delta V/V \leq \pm 10\%$ No visible damage
Operating duty cycle test *	UL 1449	6 kV/3 kA combination wave surges, phase angle of 90 (+0, -15) degrees, positive polarity 8 times, negative polarity 7 times, interval of 60s.	$\Delta V/V \leq \pm 10\%$ No visible damage
Surge Immunity Test *	IEC 61000-4-5	4kV/2kA combination wave surges, phase angle of 90 (+0, -15) degrees, positive polarity 20times, negative polarity 20 times, interval of 60s.	$\Delta V/V \leq \pm 10\%$ No visible damage

\* (According to customer requirements to meet the test items)

**Impulse Life Time Rating Curves**

**CNR-10P180K to CNR-10P680K**

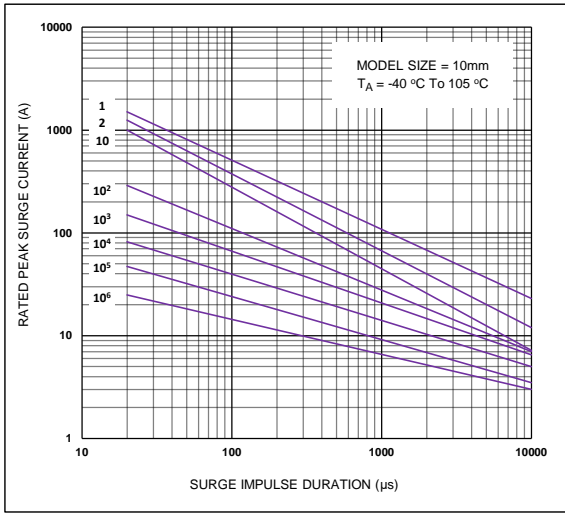

**CNR-10P201K to CNR-10P751K**

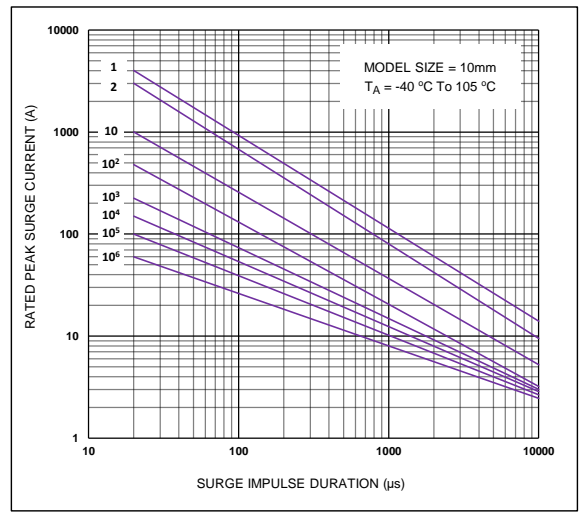

**CNR-10P781K to CNR-10P112K**

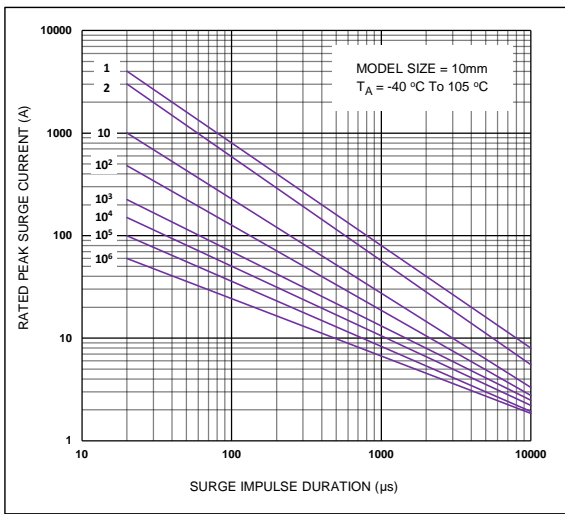

**CNR-14P180K to CNR-14P680K**

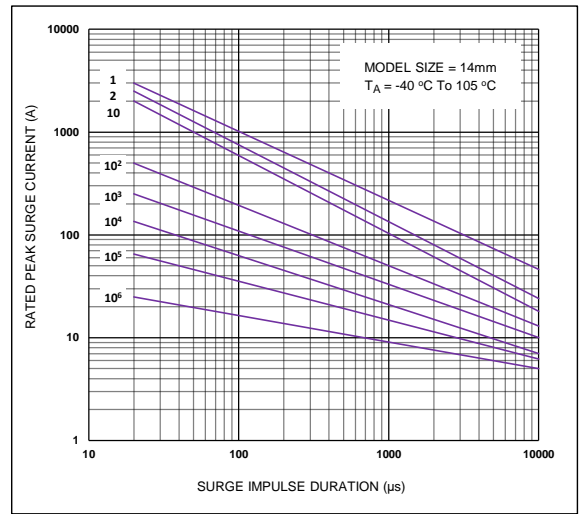



**Impulse Life Time Rating Curves**

**CNR-14P201K to CNR-14P751K**

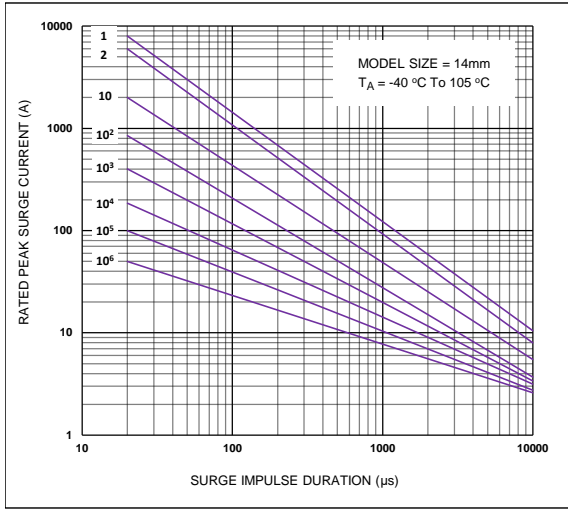

**CNR-14P781K to CNR-14P112K**

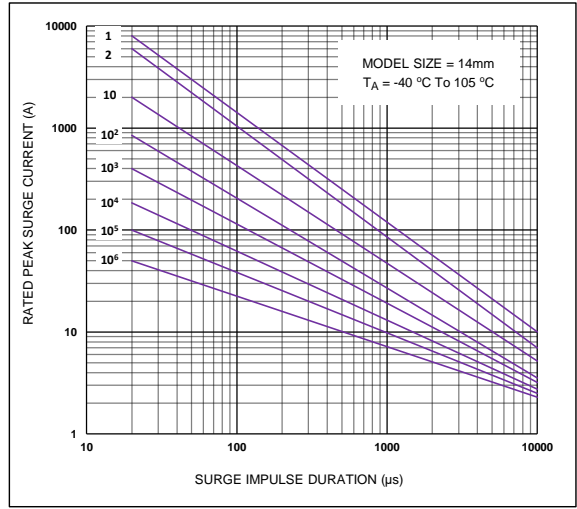

**CNR-18P180K to CNR-18P680K**

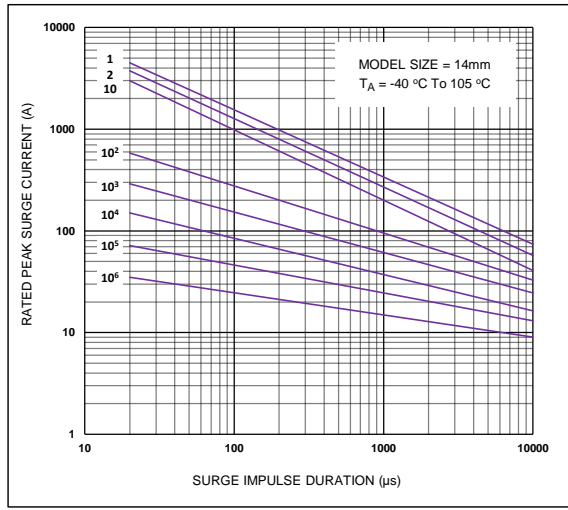

**CNR-18P201K to CNR-18P112K**

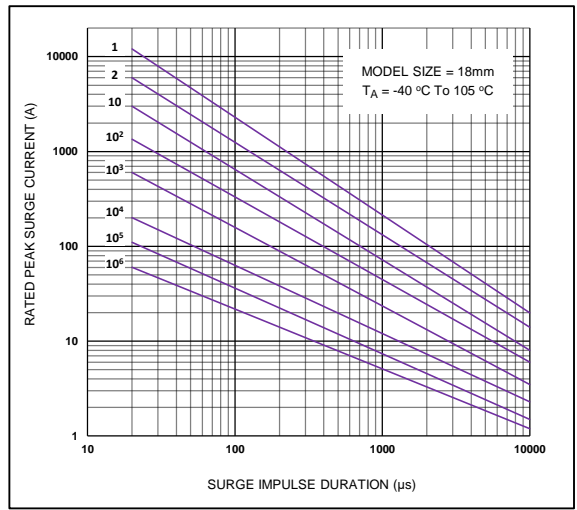

**Impulse Life Time Rating Curves**

**CNR-20P180K to CNR-20P680K**

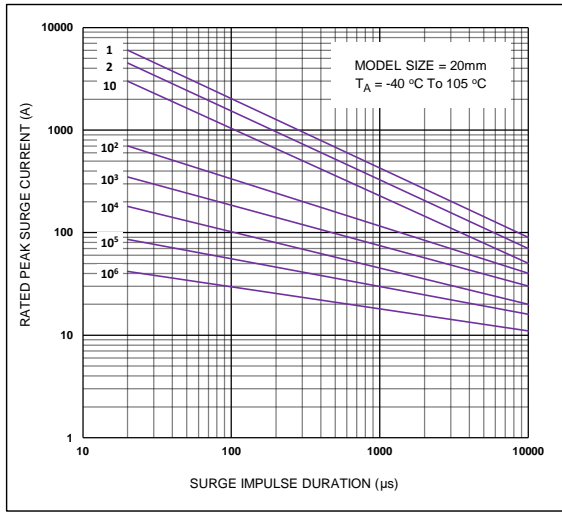

**CNR-20P201K to CNR-20P112K**

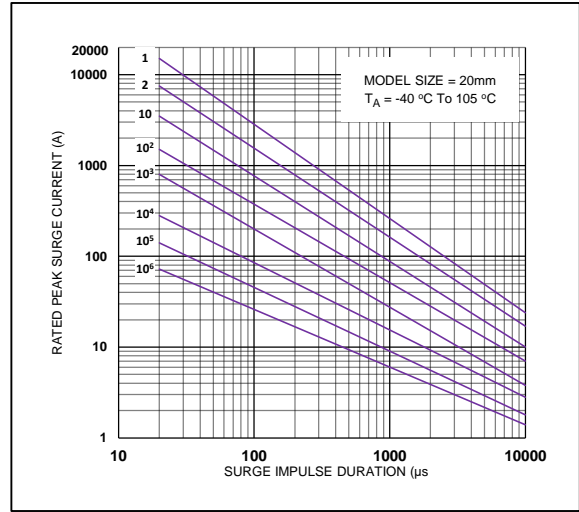

CNR-10P180K to 10P680K V-I Curves

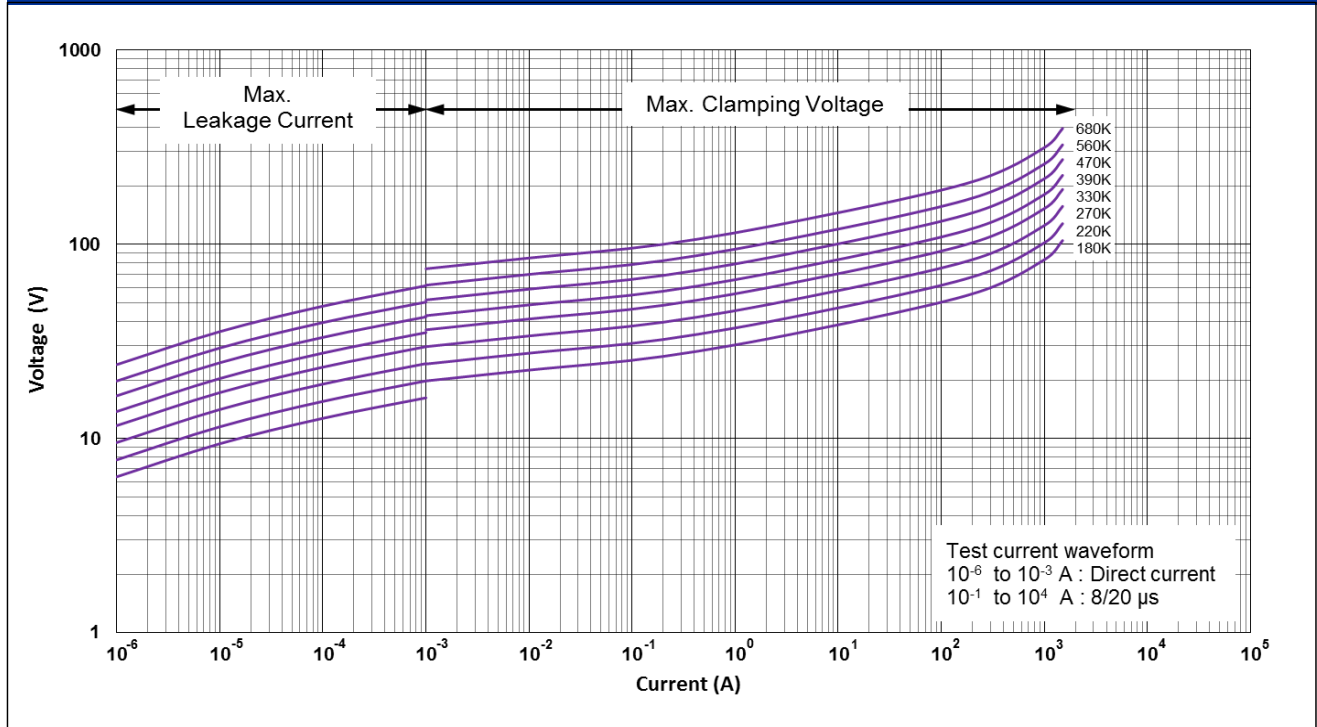

CNR-10P201K to 10P471K V-I Curves

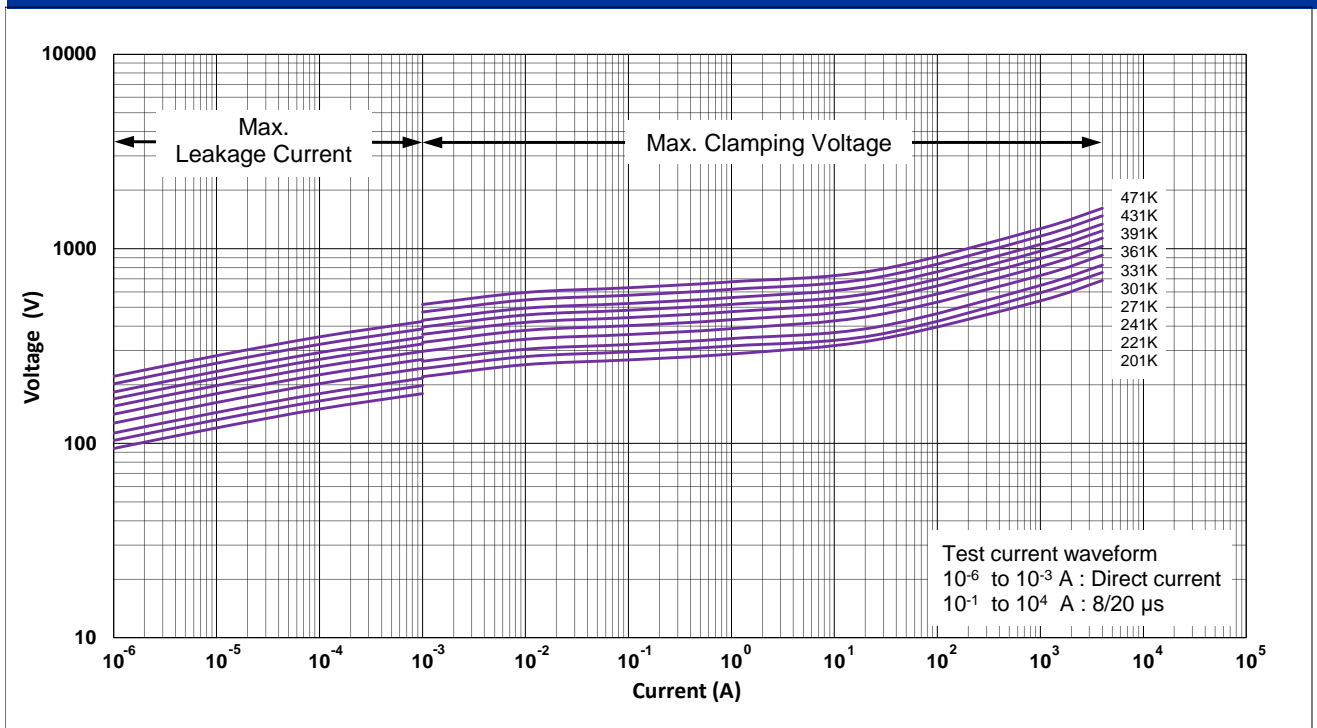

**CNR-10P511K to 10P112K V-I Curves**

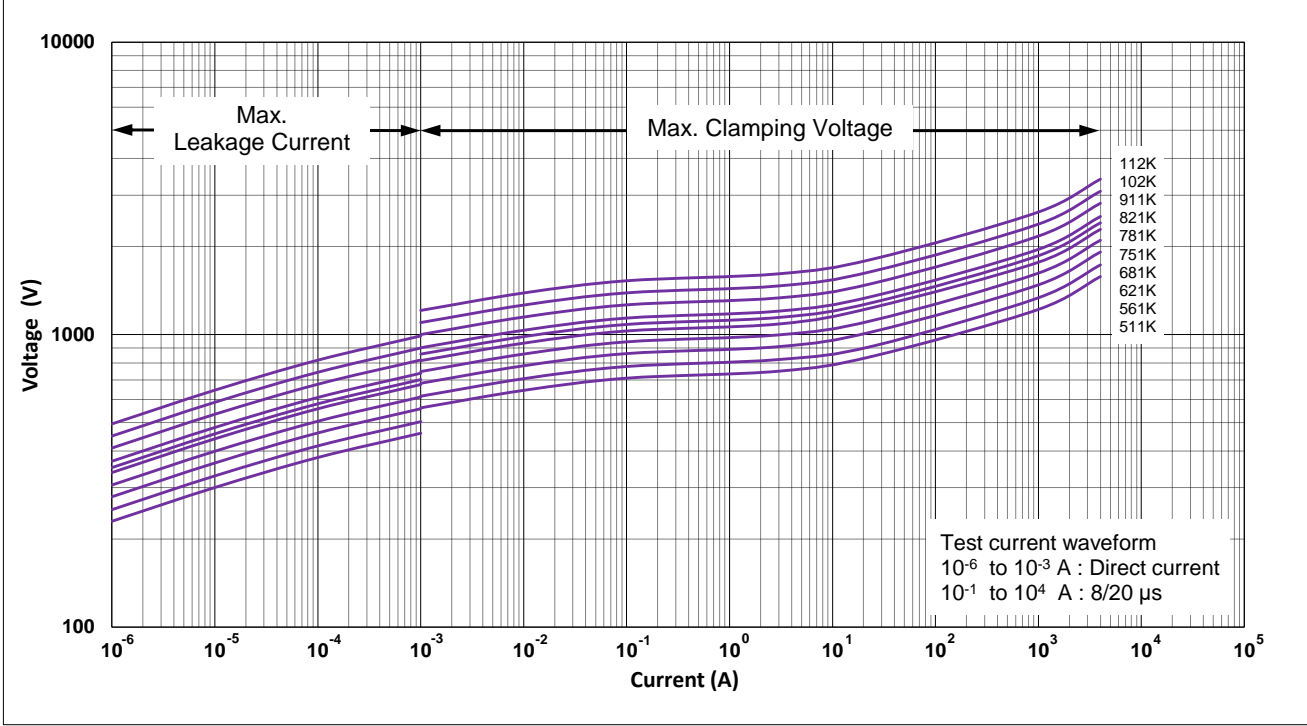

**CNR-14P180K to 14P680K V-I Curves**

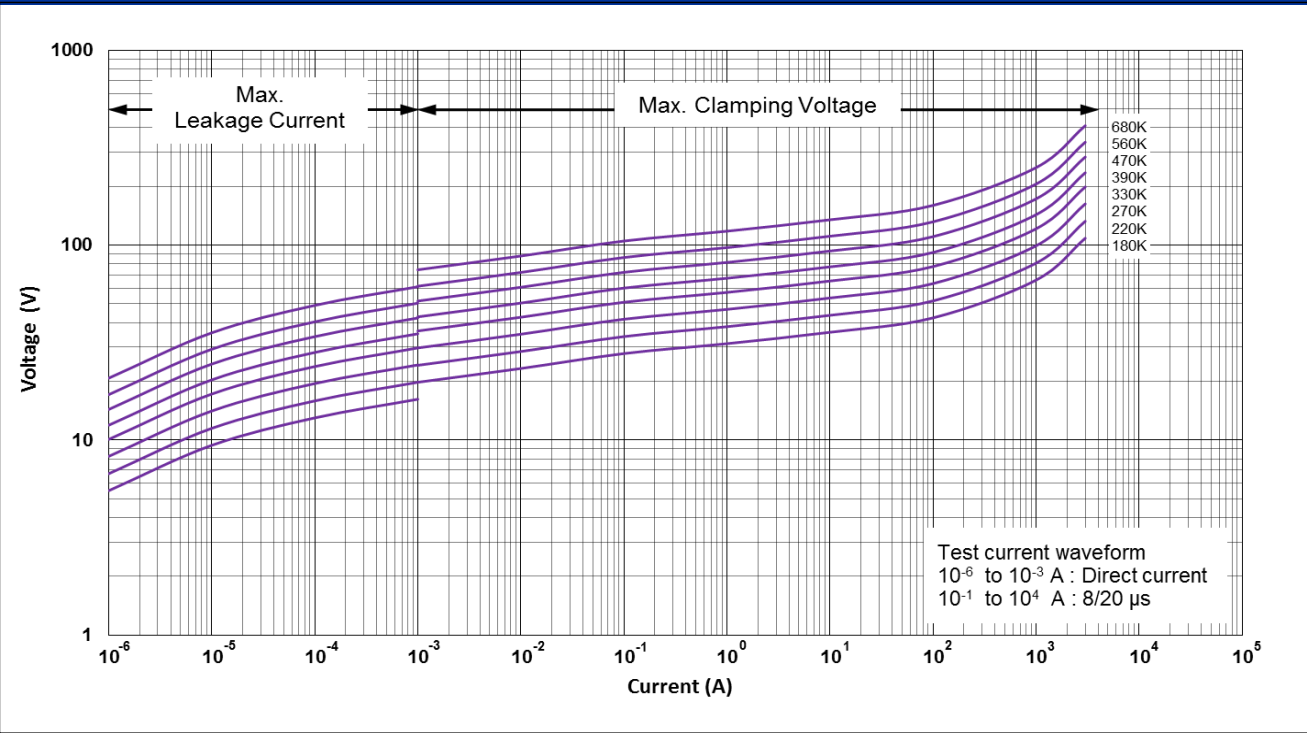

CNR-14P201K to 14P471K V-I Curves

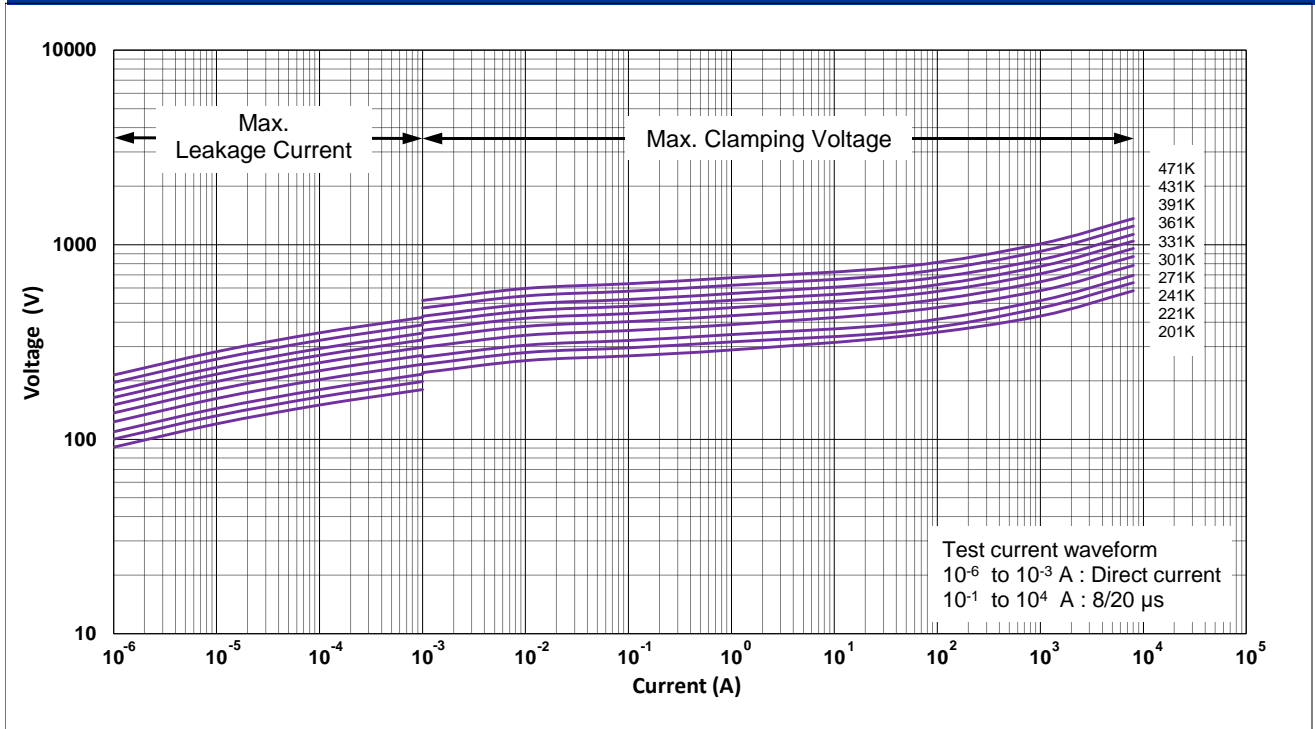

CNR- 14P511K to 14P112K V-I Curves

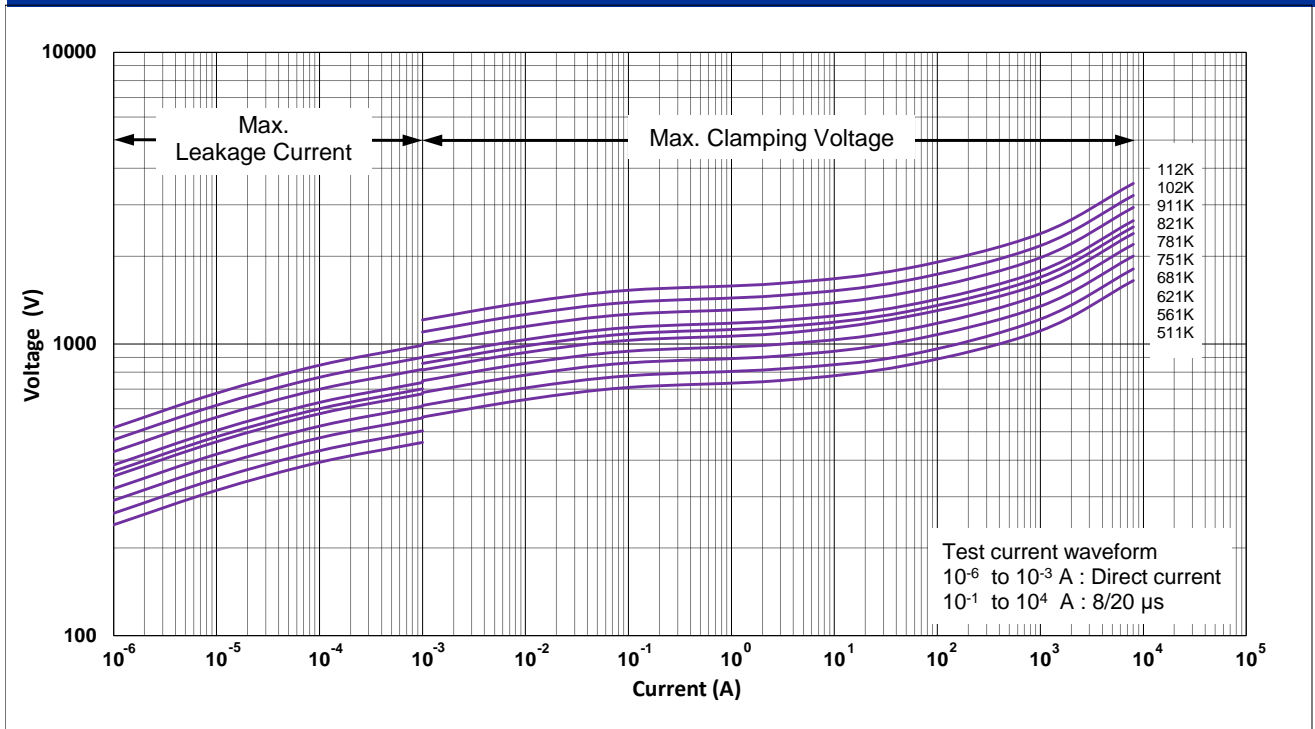

CNR-18P180K to 18P680K V-I Curves

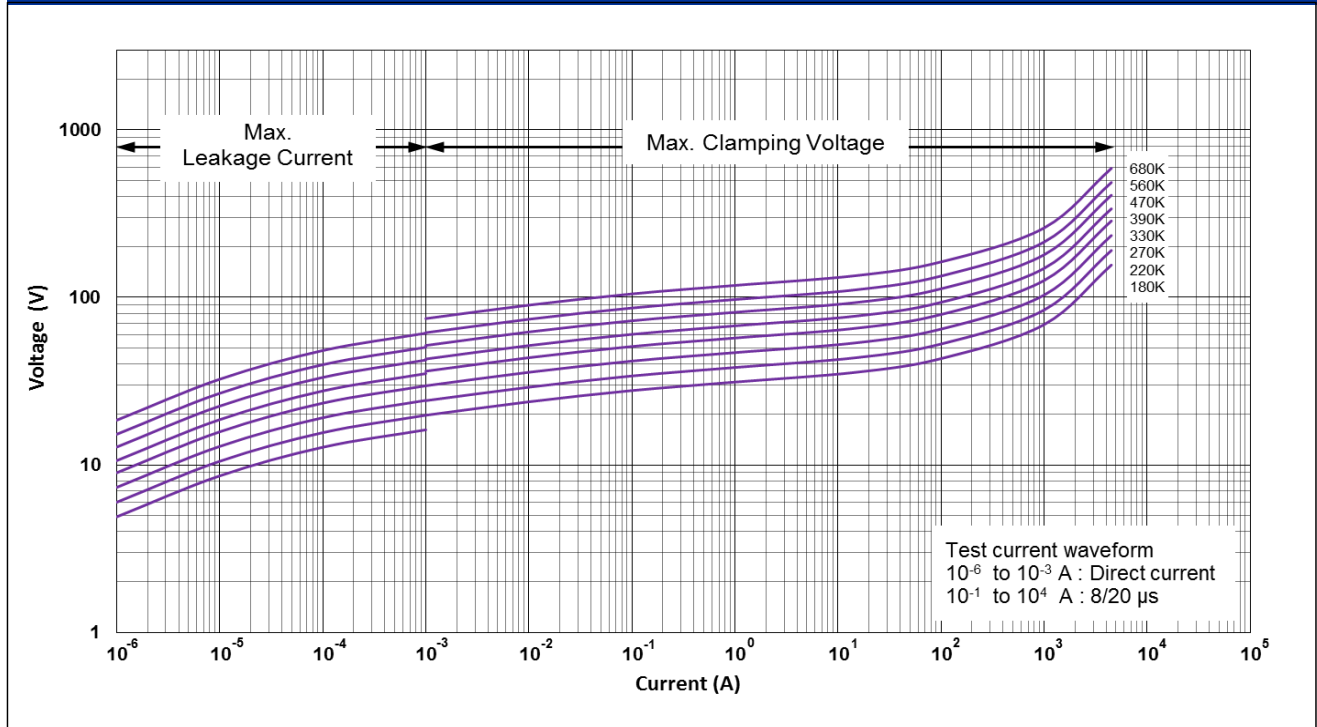

CNR-18P201K to 18P471K V-I Curves

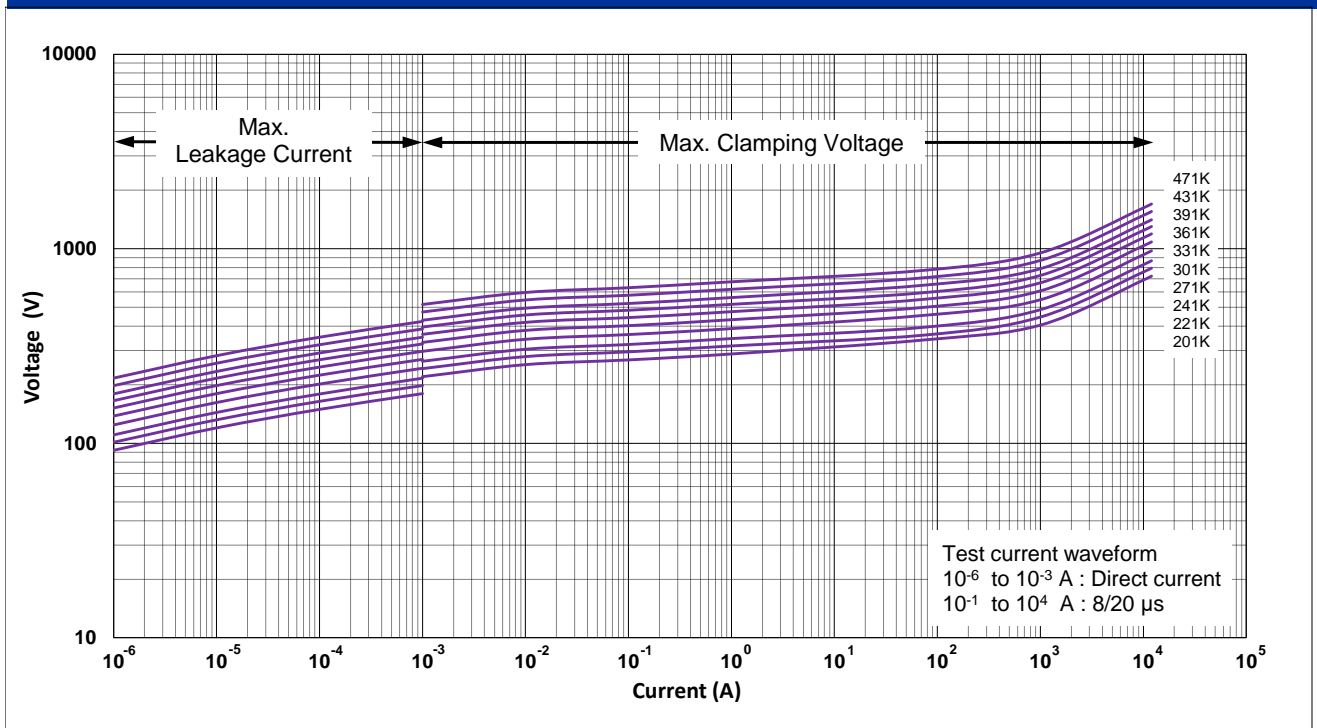

CNR-18P511K to 18P112K V-I Curves

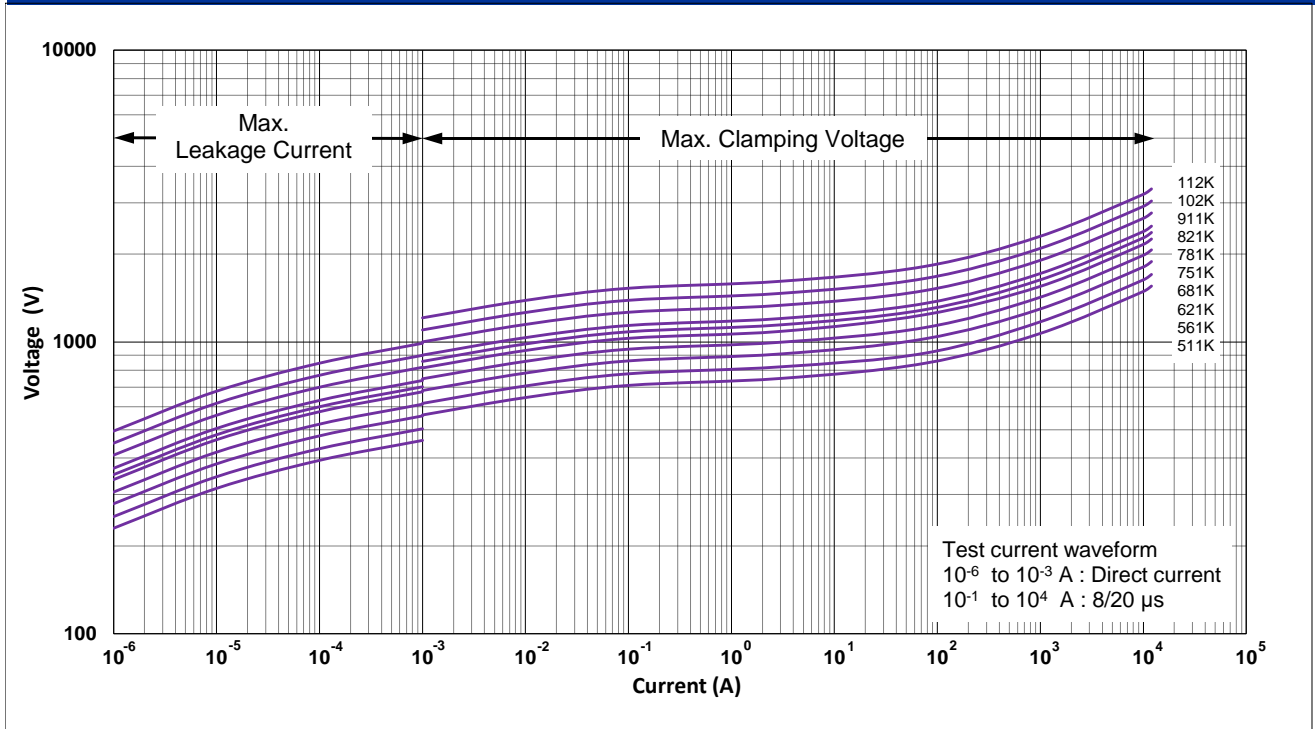

CNR-20P180K to 20P680K V-I Curves

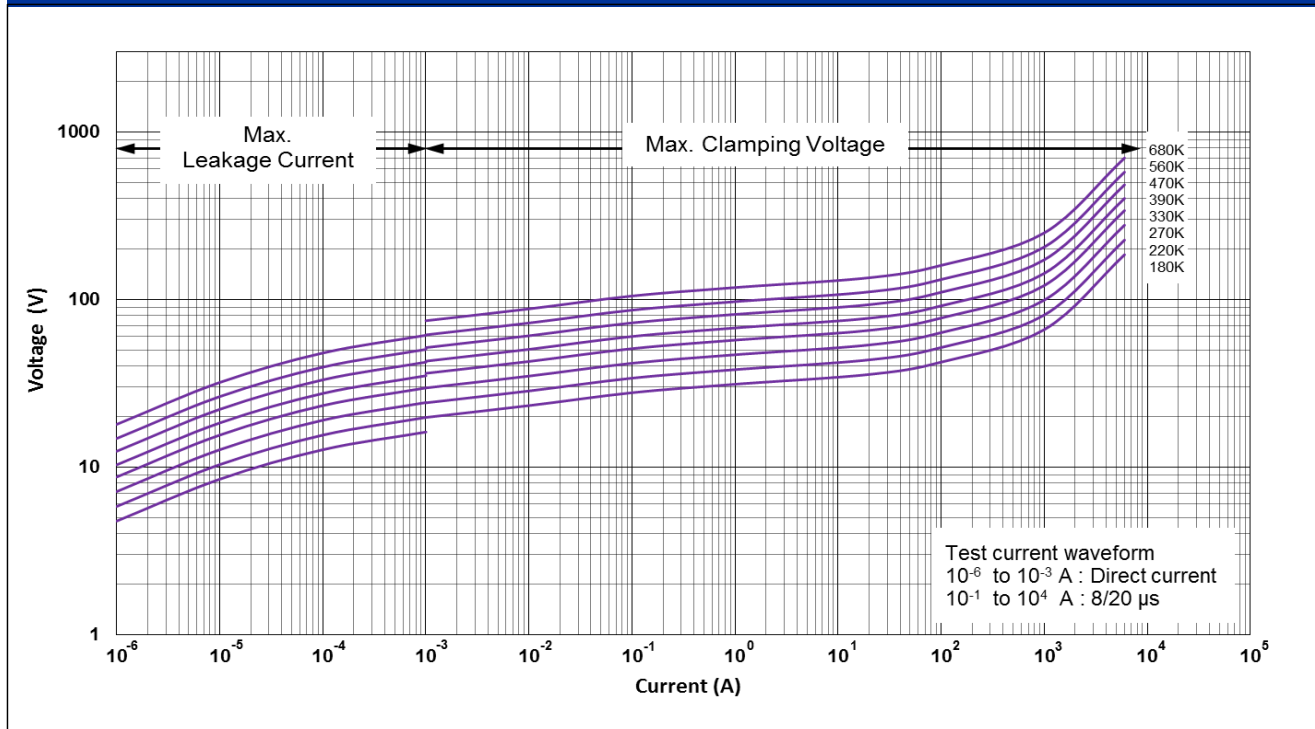

**CNR-20P201K to 20P471K V-I Curves**

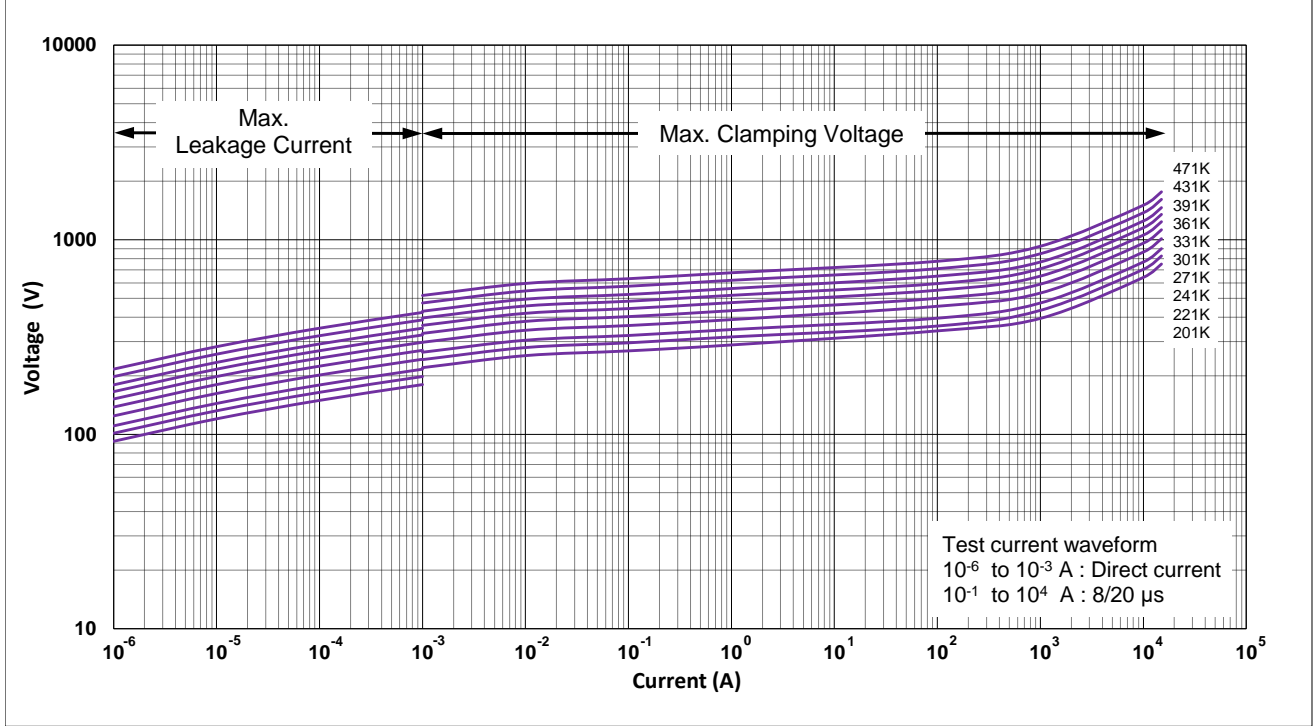

**CNR- 20P511K to 20P112K V-I Curves**

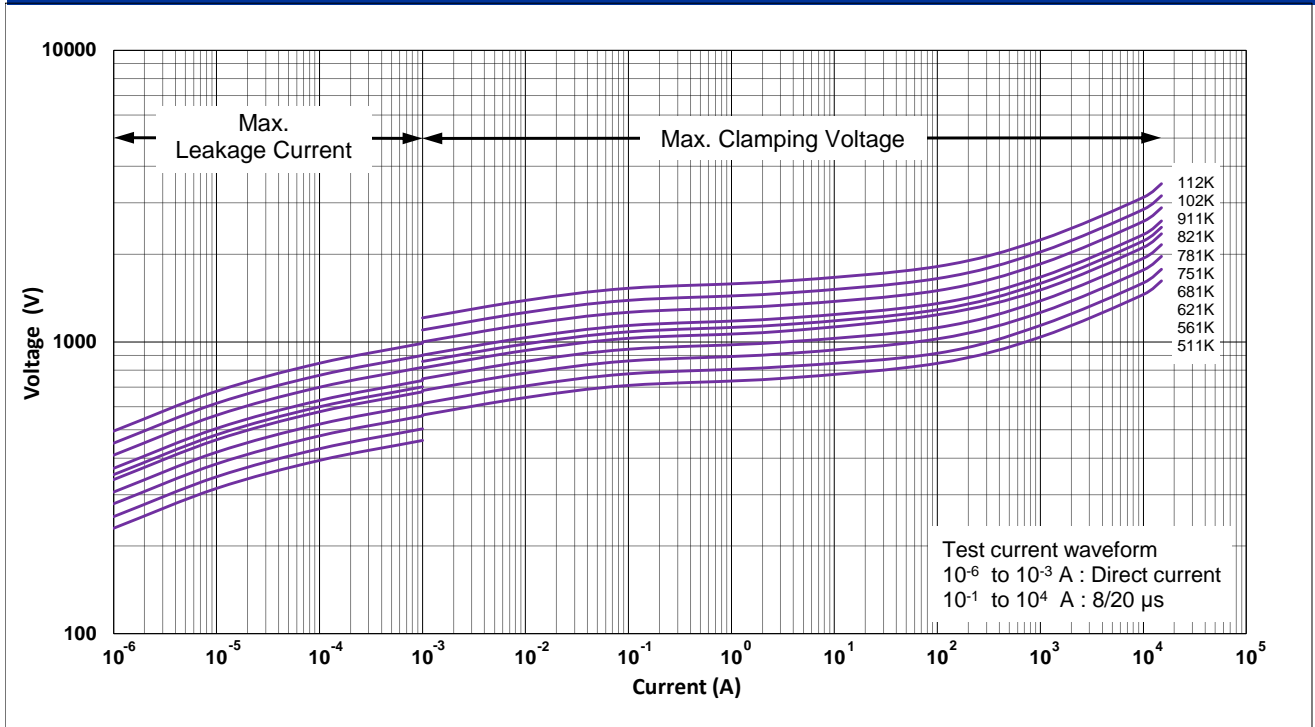



**Power Derating Curve**

Should transients occur in rapid succession, the average power dissipation is the energy (watt-seconds) per pulse times the number of pulses per second. The power so developed must be with the specifications shown on the Device Ratings and Specifications Table for the specific device. The operating values of a MOV need to be derated at high temperatures as shown above. Because varistors only dissipate a relatively small amount of average power they are not suitable for repetitive applications that involve substantial amounts of average power dissipation.

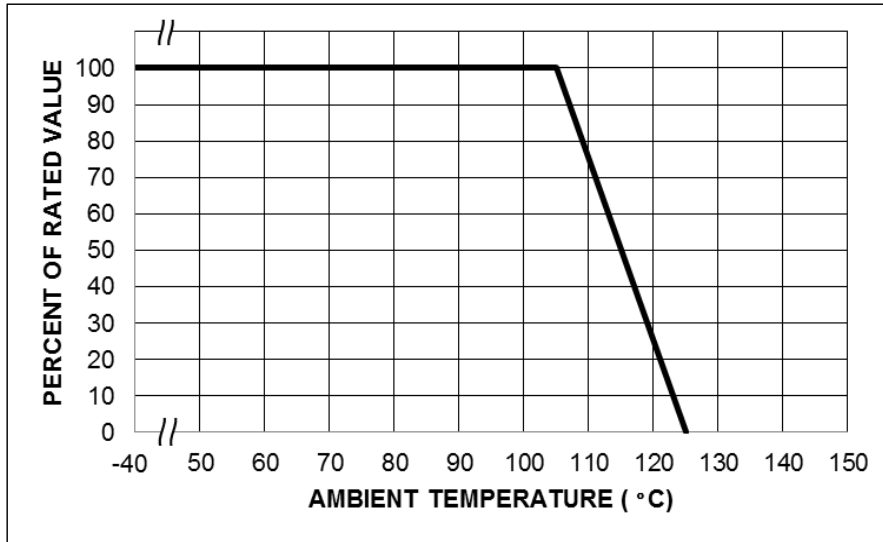

**Surge Current Standard Waveform**

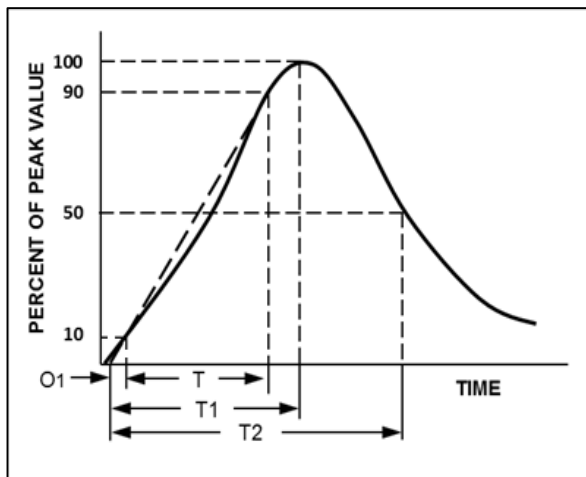

O1 = Virtual Origin of Wave  
 T = Time from 10% to 90% of Peak  
 T1 = Rise Time = 1.25 x T  
 T2 = Decay Time  
 Example - For an 8/20 μs Current Waveform:  
 8μs = T1 = Rise Time  
 20μs = T2 = Decay Time

**Product Dimensions**

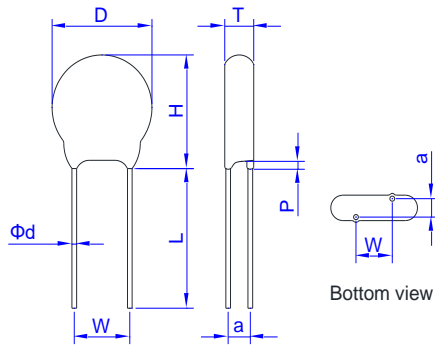

Fig 1. Straight Lead

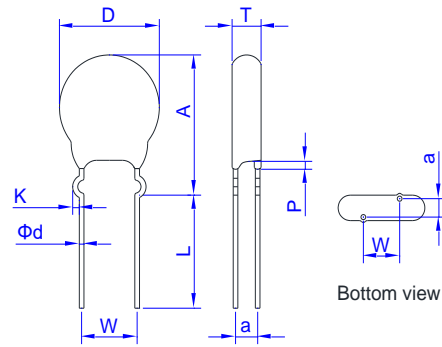

Fig 2. Outside Kink Lead

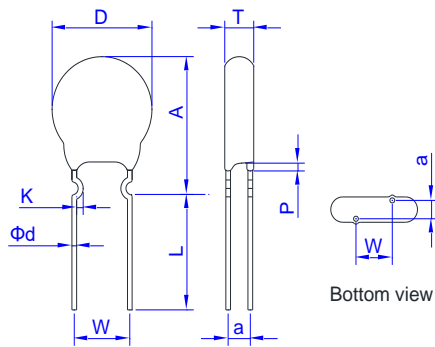

Fig 3. Inside Kink Lead

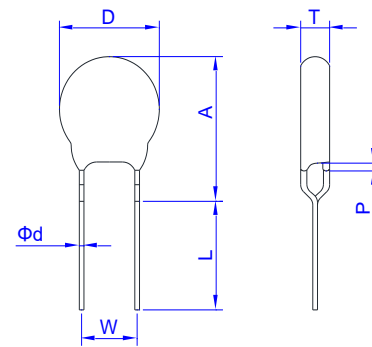

Fig 4. In Line Kink Lead

**Dimension Table**

**Unit:mm**

Symbol	Model size	10P		14P		18P		20P	
		Min.	Max.	Min.	Max.	Min.	Max.	Min.	Max.
D		10.5	14.0	13.5	17.5	18.5	23.0	19.5	25.0
H		-	17.0	-	20.5	-	26.0	-	28.0
W		6.5	8.5	6.5	8.5	6.5	8.5	9.0	11.0
Φd		0.75	0.85	0.75	0.85	0.75	0.85	0.95	1.05
P(max.)		3							
L(min)		25							
K(Kink Lead)		1.0	1.8	1.0	1.8	1.0	1.8	1.0	1.8
A(max.)	201K-271K	-	19.5	-	22.5	-	26.5	-	30.0
	>271K	-	20.5	-	23.5	-	27.0	-	31.0
T		See Tmax table							

\* Short Cut Lead type TTXX the lead length (L) can 3.0~15mm (except 20P<10mm), see Ordering Note.

\* \* a value see T max. table

T max. Table						Unit:mm					
Model	10P	14P	18P	20P	a(±1.0)	Model	10P	14P	18P	20P	a(±1.0)
180K	3.9	4.0	4.2	4.2	1.5	361K	5.4	5.5	5.5	6.0	2.1
220K	4.2	4.3	4.5	4.6	1.7	391K	5.5	5.6	5.6	6.1	2.3
270K	4.4	4.5	4.7	4.8	1.8	431K	5.7	5.8	5.8	6.4	2.4
330K	3.9	4.0	4.2	4.3	1.9	471K	5.9	6.0	6.0	6.6	2.5
390K	4.1	4.2	4.4	4.5	1.9	511K	6.1	6.2	6.2	6.7	2.6
470K	4.3	4.4	4.6	4.7	2.1	561K	6.3	6.4	6.4	6.9	2.8
560K	4.6	4.7	4.9	5.0	2.3	621K	6.5	6.6	6.6	7.2	3.1
680K	4.9	5.0	5.2	5.3	2.6	681K	6.6	6.7	6.7	7.3	3.3
201K	4.5	4.6	4.6	5.1	1.5	751K	6.8	6.9	6.9	7.5	3.6
221K	4.6	4.7	4.7	5.2	1.6	781K	7.2	7.3	7.3	7.9	3.8
241K	4.7	4.8	4.8	5.3	1.7	821K	7.4	7.5	7.5	8.1	4.0
271K	4.8	4.9	4.9	5.4	1.8	911K	7.5	7.6	7.6	8.2	4.3
301K	4.9	5.0	5.0	5.5	1.9	102K	8.0	8.1	8.1	8.7	4.6
331K	5.1	5.2	5.2	5.8	2.0	112K	8.9	9.0	9.0	9.3	5.2

**Tape and Reel Specifications**

● Radial devices on tape are supplied with straight leads, kinked leads or in-line leads

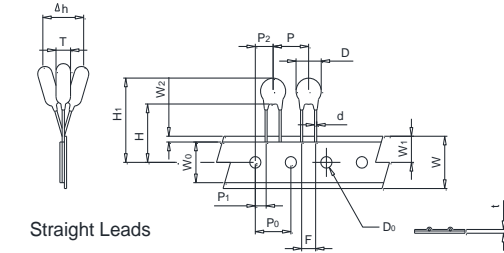

Figure: A

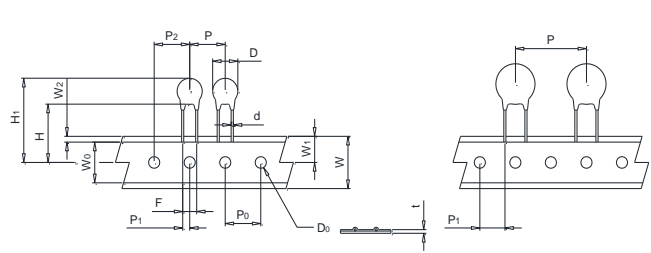

Figure: B

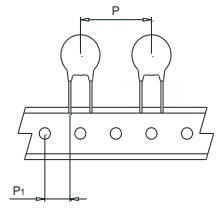

Figure: C

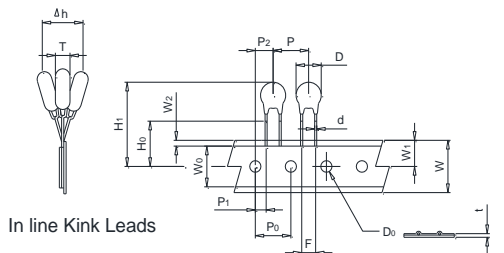

Figure: D

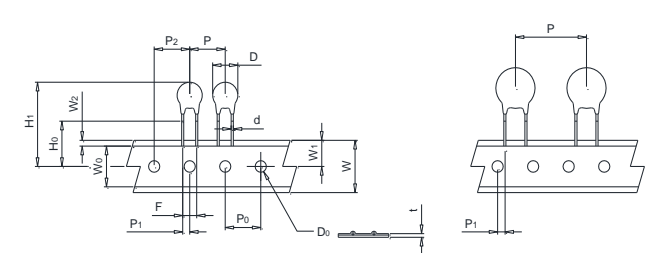

Figure: E

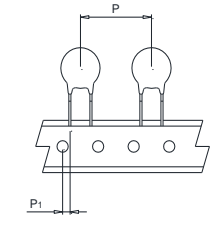

Figure: F

Symbol	Description	Model Size			
		10P	10P	14P	14P
P	Pitch of Component	12.7±1.0	15.0±1.0	25.4±1.0	30.0±1.0
P <sub>0</sub>	Feed Hole Pitch	12.7±0.2	15.0±0.2	12.7±0.2	15.0±0.2
P <sub>1</sub>	Feed Hole Center to Pitch	3.85±0.7	3.75±0.7	8.95±0.7	3.75±0.7
P <sub>2</sub>	Hole Center to Component Center	6.35±0.7	7.5±0.7	12.7±0.7	7.5±0.7
F	Lead to Lead Distance	7.5±0.8	7.5±0.8	7.5±0.8	7.5±0.8
△h	Component Alignment	2.0max	2.0max	2.0max	2.0max
W	Tape Width	18.0+1.0	18.0+1.0	18.0+1.0	18.0+1.0
		18.0-0.5	18.0-0.5	18.0-0.5	18.0-0.5
W <sub>0</sub>	Hold Down Tape Width	5.0 Min.	5.0 Min.	5.0 Min.	5.0 Min.
W <sub>1</sub>	Hole Position	9.0+0.75	9.0+0.75	9.0+0.75	9.0+0.75
		9.0-0.5	9.0-0.5	9.0-0.5	9.0-0.5
W <sub>2</sub>	Hold Down Tape Position	3.0 Max	3.0 Max	3.0 Max	3.0 Max
H	Height from Tape Center to Component Base	18.0+2.0	18.0+2.0	18.0+2.0	18.0+2.0
		18.0-0.0	18.0-0.0	18.0-0.0	18.0-0.0
H <sub>0</sub>	Seating Plane Height	16.0±0.5	16.0±0.5	16.0±0.5	16.0±0.5
H <sub>1</sub>	Component Height	36.0 Max.	36.0 Max.	40.0 Max.	40.0 Max.
D <sub>0</sub>	Feed Hole Diameter	4.0±0.2	4.0±0.2	4.0±0.2	4.0±0.2
t	Total Tape Thickness	0.7±0.2	0.7±0.2	0.7±0.2	0.7±0.2
L	Leagth Clipped Lead	11.0 Max	11.0 Max	11.0 Max	11.0 Max
Figure		B, E	A, D	C	F

**Tape and Reel Specifications**

● Radial devices on tape are supplied with straight leads, kinked leads or in -line leads

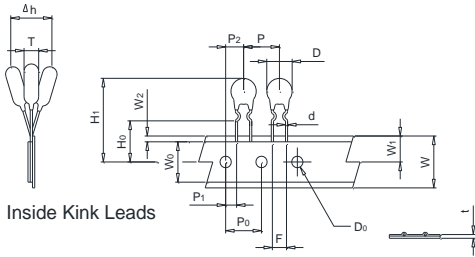

Figure: A

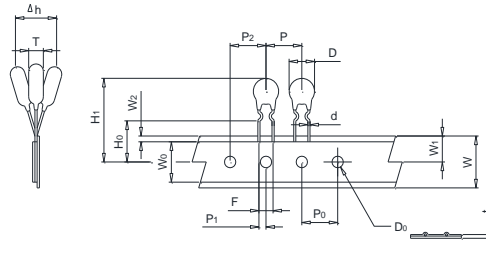

Figure: B

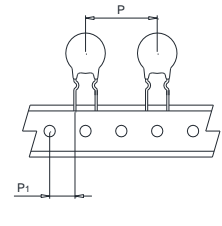

Figure: C

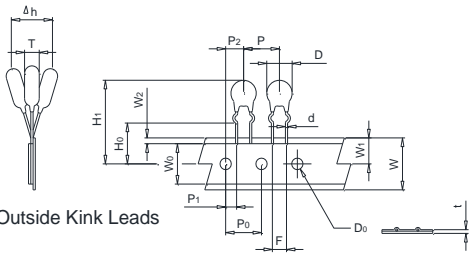

Figure: D

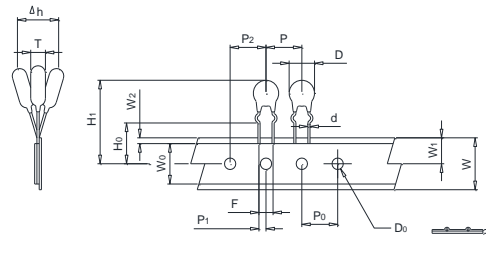

Figure: E

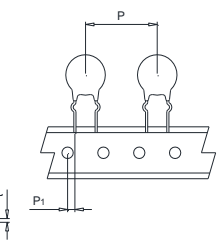

Figure: F

Symbol	Description	Model Size			
		10P	10P	14P	14P
P	Pitch of Component	12.7±1.0	15.0±1.0	25.4±1.0	30.0±1.0
P <sub>0</sub>	Feed Hole Pitch	12.7±0.2	15.0±0.2	12.7±0.2	15.0±0.2
P <sub>1</sub>	Feed Hole Center to Pitch	3.85±0.7	3.75±0.7	8.95±0.7	3.75±0.7
P <sub>2</sub>	Hole Center to Component Center	6.35±0.7	7.5±0.7	12.7±0.7	7.5±0.7
F	Lead to Lead Distance	7.5±0.8	7.5±0.8	7.5±0.8	7.5±0.8
△h	Component Alignment	2.0max	2.0max	2.0max	2.0max
W	Tape Width	18.0+1.0	18.0+1.0	18.0+1.0	18.0+1.0
		18.0-0.5	18.0-0.5	18.0-0.5	18.0-0.5
W <sub>0</sub>	Hold Down Tape Width	5.0 Min.	5.0 Min.	5.0 Min.	5.0 Min.
W <sub>1</sub>	Hole Position	9.0+0.75	9.0+0.75	9.0+0.75	9.0+0.75
		9.0-0.5	9.0-0.5	9.0-0.5	9.0-0.5
W <sub>2</sub>	Hold Down Tape Position	3.0 Max	3.0 Max	3.0 Max	3.0 Max
H	Height from Tape Center to Component Base	18.0+2.0	18.0+2.0	18.0+2.0	18.0+2.0
		18.0-0.0	18.0-0.0	18.0-0.0	18.0-0.0
H <sub>0</sub>	Seating Plane Height	16.0±0.5	16.0±0.5	16.0±0.5	16.0±0.5
H <sub>1</sub>	Component Height	36.0 Max.	36.0 Max.	40.0 Max.	40.0 Max.
D <sub>0</sub>	Feed Hole Diameter	4.0±0.2	4.0±0.2	4.0±0.2	4.0±0.2
t	Total Tape Thickness	0.7±0.2	0.7±0.2	0.7±0.2	0.7±0.2
L	Leagth Clipped Lead	11.0 Max	11.0 Max	11.0 Max	11.0 Max
Figure		B, E	A, D	C	F

**Packing information**

**Bulk packing**

Series	Straight Lead Type Quantity(pcs/bag)	Cut Lead Type Quantity(pcs/bag)	Kink Type Quantity(pcs/bag)
CNR-10P	500	500	500
CNR-14P	500	500	500
CNR-18P	250	250	250
CNR-20P	250	250	250

**Tape & Reel product packing**

Series	A (mm)	Quantity (pcs/reel)
CNR-10P(180K~391K)-TRXX	43	800
CNR-10P(431K~621K)-TRXX		700
CNR-10P(681K~112K)-TRXX		600
CNR-14P(180K~391K)-TRXX	56	800
CNR-14P(431K~621K)-TRXX		700
CNR-14P(681K~112K)-TRXX		600

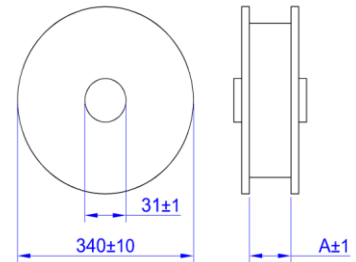

**Box product packing**

Series	Quantity (pcs/box)
CNR-10P(180K~391K)-BTXX	500
CNR-10P(431K~621K)-BTXX	500
CNR-10P(681K~112K)-BTXX	400
CNR-14P(180K~391K)-BTXX	500
CNR-14P(431K~621K)-BTXX	500
CNR-14P(681K~112K)-BTXX	400

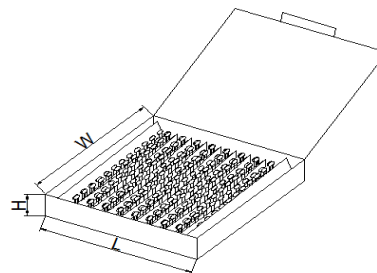

Series	L±5	W±5	H±5
CNR-10P	340	245	45
CNR-14P	340	245	50

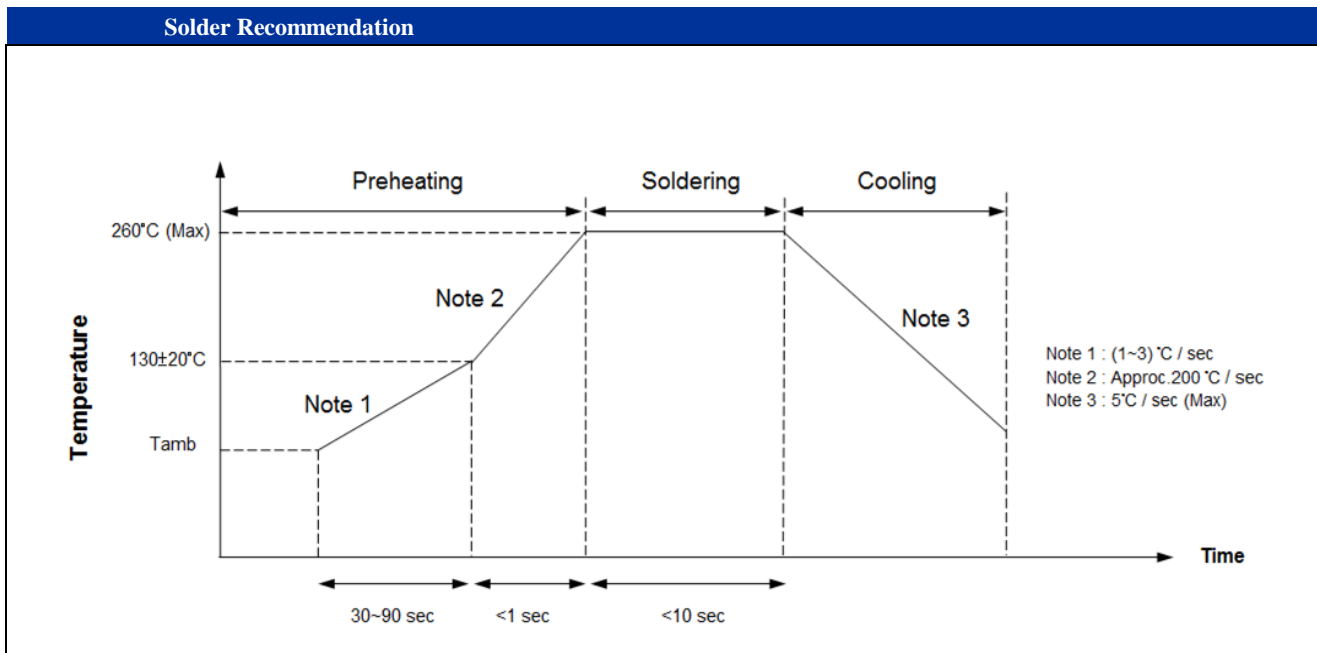

**Recommendation Reworking Conditions with Soldering Iron**

Item	Conditions
Temperature of soldering Iron-tip	360°C (Max)
Soldering Time	3 sec(Max)
Distance from Varistor	2mm(Min)

**RoHS Compliant Declaration**

We hereby declare that the components delivered to your company are compliant with RoHS Directive 2002/95/EC

- Storage Conditions of Products**
- (I) Storage Conditions:
- 1.Storage Temperature: -10°C~+40°C
  - 2.Relative Humidity: ≤75%RH
  - 3.Keep away from corrosive atmosphere and sunlight
  - 4.Solvent Resistance: MIL-STD-202, Method 215F
  - 5.Moisture Sensitivity: Level 1, J-STD-020
- (II) Period of Storage: 1 year

**Explanation of Part Numbers**

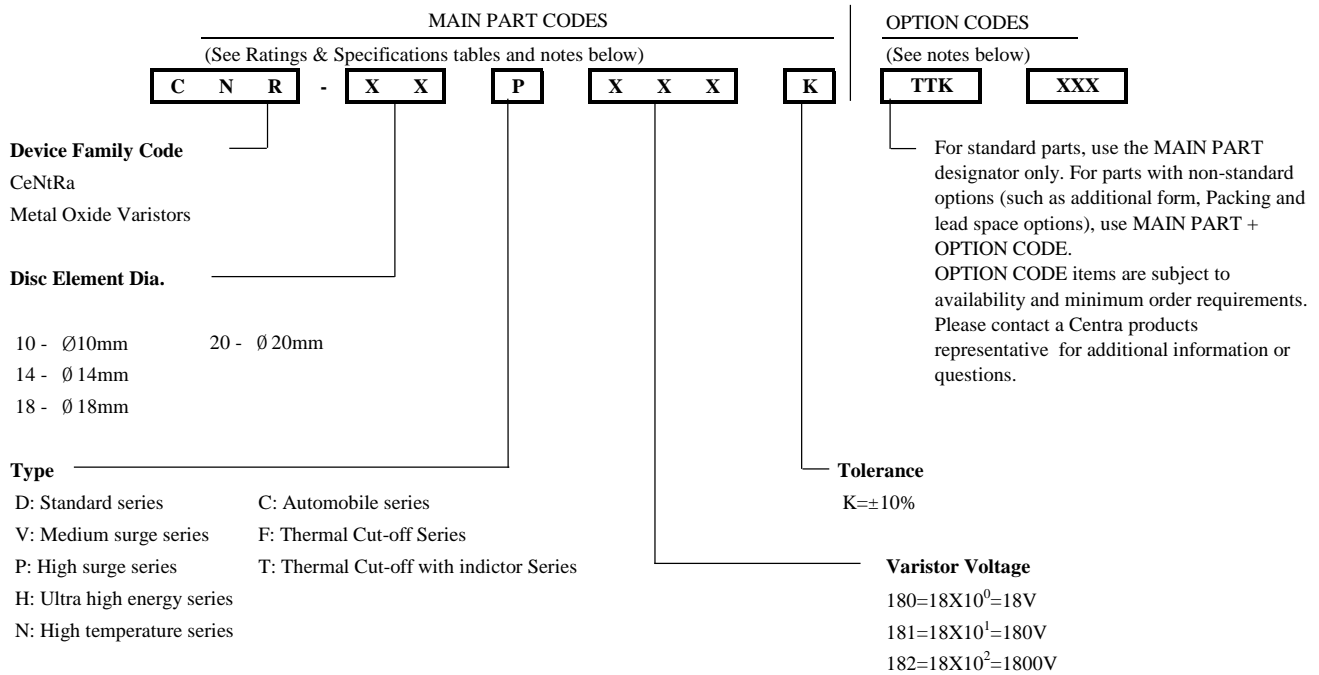

**Ordering Notes:**

**MAIN PART CODES**

Series + /Packaging/ Lead Style / Designators:

Ordering examples:

<b>Straight Lead Bulk Pack (Standard)</b>	<b>Straight Lead (Short Cut) Bulk Pack</b>	<b>Straight Lead Tape &amp; Reel Pack</b>	<b>Straight Lead Flat Box Pack</b>
CNR-10P471K	CNR-10P471KTTSXXX	CNR-10P471KTRSX	CNR-10P471KBTSX
<b>Outside Kink Lead Bulk Pack</b>	<b>Outside Kink Lead (Short Cut) Bulk Pack</b>	<b>Outside Kink Lead Tape &amp; Reel Pack</b>	<b>Outside Kink Lead Flat Box Pack</b>
CNR-10P471SOK	CNR-10P471KTTKXXX	CNR-10P471KTRKX	CNR-10P471KBTKX
<b>Inside Kink Lead Bulk Pack</b>	<b>Inside Kink Lead (Short Cut) Bulk Pack</b>	<b>Inside Kink Lead Tape &amp; Reel Pack</b>	<b>Inside Kink Lead Flat Box Pack</b>
CNR-10P471KSIK	CNR-10P471KTTIXXX	CNR-10P471KTRIX	CNR-10P471KBTIX
<b>In Line Kink Lead Bulk Pack</b>	<b>In Line Kink Lead (Short Cut) Bulk Pack</b>	<b>In Line Kink Lead Tape &amp; Reel Pack</b>	<b>In Line Kink Lead Flat Box Pack</b>
CNR-10P471KSHK	CNR-10P471KTTHXXX	CNR-10P471KTRHX	CNR-10P471KBTHX

**Option Code**

+ XXX

<b>Short Cut Lead Length 10mm±1.0mm</b>
CNR-10P471KTTTS10

<b>Tape &amp; Reel Pack Feed Hole Pitch</b>
CNR-10P471KTRSA
CNR-10P471KTRSB

A: P<sub>0</sub> → 12.7mm±0.2mm  
B: P<sub>0</sub> → 15.0mm±0.2mm

CeNtRa P Series varistors are shipped standard in bulk pack with straight leads or Kink lead and lead spacing outlined in the Package Dimensions section of this data sheet. Contact your CeNtRa sales representative to discuss non-standard options.