

**Description**

Circuits including a capacitor, filament for a bulb, inverter for fluorescent lamp, a heater and etc., induce an inrush current more than 100 times the normal current when the circuit switch is turned on. The NTC thermistors specially developed for this application limit the current at turn-on by their relatively high cold resistance. During continuous operation, the NTC thermistors heats up and its resistance remains negligibly low.

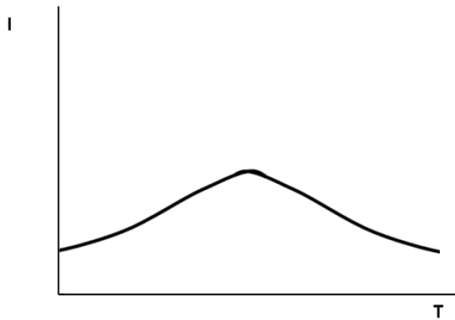

with NTC

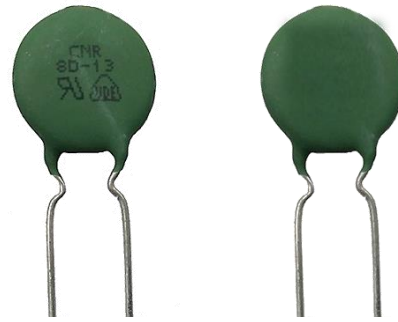
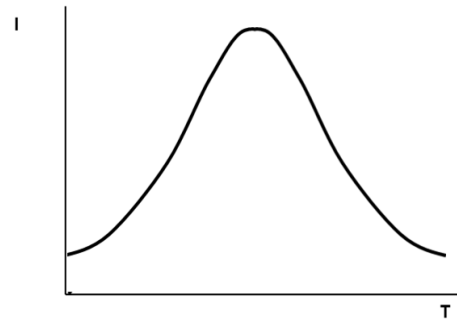

without NTC

**Agency Approvals**

Agency	Agency Approval	Certificate No.
	UL 1434 & cUL	E346014
	IEC 60539-1	40036429 40036748
	GB/T6663.1	CQC13001099647 CQC13001099648 CQC13001099649

**Features**

1. RoHS compliant
2. Small size, strong power
3. Wide resistance range
4. Fast thermal respond speed
5. High B-value, low residual resistance
6. Temperature range: -40°C ~+200°C
7. Safe, high reliability

**Applications**

1. Switch mode power supply
2. Electric motor
3. Transformer
4. Adapter
5. Projector
6. Halogen lamp
7. LED driver circuit



**Max. Rating**



	PN - Series	Units
Zero Power Resistance at 25°C	0.7 to 400	Ω
Max. Steady State Current at 25°C	0.1 to 12	A
Approx. Resistance at 25°C I <sub>max</sub>	0.054 to 30.30	Ω
Max. Power Rating at 25°C	1.8 to 7	W
Operating Temperature Range	-40 to +200	°C

**Main Technology Parameter**

Part No.	Zero Power Resistance at 25°C	Max. Steady State Current at 25°C	Approx. Resistance at 25°C I <sub>max</sub>	Max. Power Rating at 25°C	Dissipation Factor	Thermal Time Constant	Operating Temperature Range	Safety
	R <sub>25</sub> (Ω)	I <sub>max</sub> (A)	R <sub>I<sub>max</sub></sub> (Ω)	P <sub>max</sub> (W)	δ(mW/°C)	τ(Sec.)	TL~TU(°C)	
PN4R7D5	4.7	1.0	0.896	1.8	≅ 15	≅ 17	-40~150	□
PN5D5	5	1.0	0.943					□
PN6R8D5	6.8	0.8	1.170					□
PN7D5	7	0.8	1.215					□
PN8D5	8	0.7	1.480					□
PN10D5	10	0.7	1.447					□
PN12D5	12	0.6	1.913					□
PN20D5	20	0.2	7.854					□
PN60D5	60	0.5	1.878					☆
PN200D5	200	0.1	18.700					△
PN4R7D7	4.7	1.5	0.602					2.3
PN5D7	5	2.0	0.283	□				
PN6R8D7	6.8	1.0	0.699	▽				
PN7D7	7	1.0	0.731	□				
PN8D7	8	1.0	0.823	□				
PN10D7	10	1.0	0.856	□				
PN12D7	12	1.0	0.916	□				
PN15D7	15	0.4	3.250	□				
PN16D7	16	0.7	1.003	□				
PN20D7	20	0.3	4.546	□				
PN22D7	22	0.6	1.108	□				
PN25D7	25	0.3	6.295	□				
PN33D7	33	0.5	1.485	□				
PN200D7	200	0.2	11.650	◎				

**Related Standards**







Symbols	□	☆	◎
Approval			



Symbols	▽	△
Approval		

Main Technology Parameter

Part No.	Zero Power Resistance at 25°C	Max. Steady State Current at 25°C	Approx. Resistance at 25°C I <sub>max</sub>	Max. Power Rating at 25°C	Dissipation Factor	Thermal Time Constant	Operating Temperature Range	Safety
	R <sub>25</sub> (Ω)	I <sub>max</sub> (A)	R <sub>I<sub>max</sub></sub> (Ω)	P <sub>max</sub> (W)	δ(mW/°C)	τ(Sec.)	TL~TU(°C)	
PN3D9	3	3.0	0.205	2.4	≐17	≐43	-40~170	☆
PN4D9	4	3.0	0.190					☆
PN4R7D9	4.7	2.5	0.266					□
PN5D9	5	2.5	0.272					□
PN6D9	6	2.2	0.287					□
PN6R8D9	6.8	2.0	0.702					□
PN7D9	7	2.0	0.724					□
PN8D9	8	1.3	0.635					□
PN10D9	10	0.7	1.408					□
PN12D9	12	1.0	0.652					□
PN15D9	15	0.4	2.869					□
PN16D9	16	1.0	0.802					□
PN20D9	20	0.3	2.884					□
PN22D9	22	1.0	0.950					□
PN25D9	25	0.3	4.416					□
PN30D9	30	1.0	1.022					□
PN33D9	33	1.0	1.124					□
PN50D9	50	1.0	1.252					□
PN60D9	60	0.8	1.502					□
PN80D9	80	0.8	2.010					□
PN120D9	120	0.8	3.015	◎				
PN200D9	200	0.5	5.007	◎				
PN400D9	400	0.2	30.300	◎				

Related Standards

Symbols	□	☆	◎
Approval	  	 	 

Symbols	▽	△
Approval	 	

Main Technology Parameter

Part No.	Zero Power Resistance at 25°C	Max. Steady State Current at 25°C	Approx. Resistance at 25°C I <sub>max</sub>	Max. Power Rating at 25°C	Dissipation Factor	Thermal Time Constant	Operating Temperature Range	Safety
	R <sub>25</sub> (Ω)	I <sub>max</sub> (A)	R <sub>I<sub>max</sub></sub> (Ω)	P <sub>max</sub> (W)	δ(mW/°C)	τ(Sec.)	T <sub>L</sub> ~T <sub>U</sub> (°C)	
PN1D11	1	4.5	0.105	2.4	≅ 17	≅ 43	-40~170	<input type="checkbox"/>
PN1R3D11	1.3	4.5	0.112					<input type="checkbox"/>
PN1R5D11	1.5	4.5	0.119					<input type="checkbox"/>
PN2D11	2	4.0	0.130					<input type="checkbox"/>
PN2R2D11	2.2	4.0	0.136					<input type="checkbox"/>
PN2R5D11	2.5	3.5	0.133					<input type="checkbox"/>
PN3D11	3	3.5	0.198					<input type="checkbox"/>
PN3R3D11	3.3	3.5	0.137					<input type="checkbox"/>
PN4D11	4	3.5	0.160					<input type="checkbox"/>
PN4R7D11	4.7	2.5	0.274					<input type="checkbox"/>
PN5D11	5	3.5	0.166					<input type="checkbox"/>
PN6D11	6	3.0	0.232					<input type="checkbox"/>
PN6R8D11	6.8	2.2	0.335					<input type="checkbox"/>
PN7D11	7	2.2	0.369					<input type="checkbox"/>
PN8D11	8	3.0	0.248					<input type="checkbox"/>
PN10D11	10	3.0	0.275					<input type="checkbox"/>
PN12D11	12	1.5	0.832					<input type="checkbox"/>
PN13D11	13	2.0	0.564					<input type="checkbox"/>
PN15D11	15	2.0	0.591					<input type="checkbox"/>
PN16D11	16	1.5	0.851					<input type="checkbox"/>
PN20D11	20	1.5	0.932					<input type="checkbox"/>
PN22D11	22	1.5	1.030					<input type="checkbox"/>
PN25D11	25	1.2	1.223					<input type="checkbox"/>
PN30D11	30	1.0	1.440					<input type="checkbox"/>
PN33D11	33	1.0	1.534					<input type="checkbox"/>
PN47D11	47	1.0	1.695					<input type="checkbox"/>
PN50D11	50	1.0	1.726					<input type="checkbox"/>
PN60D11	60	1.0	2.069					<input type="checkbox"/>
PN80D11	80	1.0	2.236					<input type="checkbox"/>
PN100D11	100	0.4	5.800					<input checked="" type="checkbox"/>

Related Standards

Symbols	<input type="checkbox"/>	<input type="checkbox"/>	<input type="checkbox"/>	<input type="checkbox"/>	<input type="checkbox"/>	<input type="checkbox"/>	<input type="checkbox"/>
Approval							

Symbols	<input type="checkbox"/>	<input type="checkbox"/>
Approval		

Main Technology Parameter

Part No.	Zero Power Resistance at 25°C	Max. Steady State Current at 25°C	Approx. Resistance at 25°C I <sub>max</sub>	Max. Power Rating at 25°C	Dissipation Factor	Thermal Time Constant	Operating Temperature Range	Safety
	R <sub>25</sub> (Ω)	I <sub>max</sub> (A)	R <sub>I<sub>max</sub></sub> (Ω)	P <sub>max</sub> (W)	δ(mW/°C)	τ(Sec.)	T <sub>L</sub> ~T <sub>U</sub> (°C)	
PN1D13	1	6.0	0.084	3.1	≐ 18	≐ 66	-40~+200	<input type="checkbox"/>
PN1R3D13	1.3	6.0	0.085					<input type="checkbox"/>
PN2D13	2	4.0	0.197					<input type="checkbox"/>
PN2R2D13	2.2	4.0	0.219					<input type="checkbox"/>
PN2R5D13	2.5	5.0	0.131					<input type="checkbox"/>
PN3D13	3	3.5	0.229					<input type="checkbox"/>
PN3R3D13	3.3	3.5	0.250					<input type="checkbox"/>
PN4D13	4	4.0	0.196					<input type="checkbox"/>
PN4R7D13	4.7	3.0	0.224					<input type="checkbox"/>
PN5D13	5	4.0	0.249					<input type="checkbox"/>
PN6R8D13	6.8	2.5	0.323					<input type="checkbox"/>
PN7D13	7	3.5	0.245					<input type="checkbox"/>
PN8D13	8	3.5	0.273					<input type="checkbox"/>
PN10D13	10	3.5	0.291					<input type="checkbox"/>
PN12D13	12	3.5	0.308					<input type="checkbox"/>
PN15D13	15	2.5	0.484					<input type="checkbox"/>
PN16D13	16	2.5	0.491					<input type="checkbox"/>
PN18D13	18	2.5	0.518					<input type="checkbox"/>
PN20D13	20	2.5	0.586					<input type="checkbox"/>
PN22D13	22	1.5	0.912					<input type="checkbox"/>
PN25D13	25	1.5	1.090					<input type="checkbox"/>
PN30D13	30	2.3	0.626					<input type="checkbox"/>
PN47D13	47	1.7	1.118					<input type="checkbox"/>
PN50D13	50	1.0	2.227					<input type="checkbox"/>
PN80D13	80	0.8	3.390					<input type="checkbox"/>
PN100D13	100	0.6	5.325					<input type="checkbox"/>
PN120D13	120	1.2	3.186					<input type="checkbox"/>

Related Standards







Symbols	<input type="checkbox"/>	<input type="checkbox"/>	<input type="checkbox"/>	<input type="checkbox"/>	<input type="checkbox"/>	<input type="checkbox"/>	<input type="checkbox"/>
Approval							



Symbols	<input type="checkbox"/>	<input type="checkbox"/>
Approval		

**Main Technology Parameter**

Part No.	Zero Power Resistance at 25°C	Max. Steady State Current at 25°C	Approx. Resistance at 25°C I <sub>max</sub>	Max. Power Rating at 25°C	Dissipation Factor	Thermal Time Constant	Operating Temperature Range	Safety
	R <sub>25</sub> (Ω)	I <sub>max</sub> (A)	R <sub>I<sub>max</sub></sub> (Ω)	P <sub>max</sub> (W)	δ(mW/°C)	τ(Sec.)	T <sub>L</sub> ~T <sub>U</sub> (°C)	
PNR7D15	0.7	6.0	0.108	3.6	≐21	≐75	-40~+200	☆
PN1D15	1	6.0	0.115					□
PN1R3D15	1.3	5.5	0.148					□
PN1R5D15	1.5	5.5	0.094					□
PN2D15	2	5.0	0.124					□
PN2R2D15	2.2	5.0	0.140					□
PN2R5D15	2.5	5.0	0.155					□
PN3D15	3	4.5	0.158					□
PN3R3D15	3.3	4.5	0.172					□
PN4D15	4	4.0	0.195					□
PN4R7D15	4.7	3.5	0.206					□
PN5D15	5	3.5	0.211					□
PN6D15	6	3.5	0.217					□
PN6R8D15	6.8	3.0	0.253					□
PN7D15	7	3.0	0.268					□
PN8D15	8	3.0	0.275					□
PN10D15	10	2.75	0.323					□
PN12D15	12	2.75	0.336					□
PN15D15	15	2.5	0.422					□
PN16D15	16	2.5	0.429					□
PN18D15	18	2.5	0.444					□
PN20D15	20	2.5	0.461					□
PN22D15	22	2.5	0.501					□
PN25D15	25	2.5	0.510					□
PN30D15	30	2.0	0.692					□
PN33D15	33	2.0	0.715					□
PN40D15	40	1.2	1.441					□
PN47D15	47	1.2	1.465					□
PN80D15	80	1.2	1.720					☆
PN120D15	120	1.2	2.097					△

**Related Standards**







Symbols	□	☆	◎
Approval	      		



Symbols	▽	△
Approval	  	

Main Technology Parameter

Part No.	Zero Power Resistance at 25°C	Max. Steady State Current at 25°C	Approx. Resistance at 25°C I <sub>max</sub>	Max. Power Rating at 25°C	Dissipation Factor	Thermal Time Constant	Operating Temperature Range	Safety
	R <sub>25</sub> (Ω)	I <sub>max</sub> (A)	R <sub>I<sub>max</sub></sub> (Ω)	P <sub>max</sub> (W)	δ(mW/°C)	τ(Sec.)	TL~TU(°C)	
PNR7D20	0.7	8.5	0.063	4.9	≐28	≐113	-40~+200	☆
PN1D20	1	8.5	0.066					□
PN1R5D20	1.5	8.0	0.081					□
PN2D20	2	7.5	0.125					□
PN2R5D20	2.5	7.0	0.160					□
PN3D20	3	6.5	0.153					□
PN3R3D20	3.3	6.5	0.161					▽
PN4D20	4	6.0	0.159					□
PN4R7D20	4.7	5.5	0.235					☆
PN5D20	5	5.5	0.243					□
PN6D20	6	5.0	0.254					▽
PN6R8D20	6.8	5.0	0.265					□
PN7D20	7	5.0	0.269					□
PN8D20	8	5.0	0.300					□
PN10D20	10	4.5	0.360					□
PN12D20	12	4.5	0.355					□
PN13D20	13	3.5	0.501					□
PN15D20	15	3.0	0.600					□
PN16D20	16	3.0	0.691					□
PN18D20	18	2.5	0.742					□
PN20D20	20	2.5	0.823	□				

Related Standards

Symbols	□	☆	◎
Approval	  	 	 

Symbols	▽	△
Approval	 	

Main Technology Parameter

Part No.	Zero Power Resistance at 25°C	Max. Steady State Current at 25°C	Approx. Resistance at 25°C I <sub>max</sub>	Max. Power Rating at 25°C	Dissipation Factor	Thermal Time Constant	Operating Temperature Range	Safety
	R <sub>25</sub> (Ω)	I <sub>max</sub> (A)	R <sub>I<sub>max</sub></sub> (Ω)	P <sub>max</sub> (W)	δ(mW/°C)	τ(Sec.)	TL~TU(°C)	
PN1D25	1	12.0	0.054	7	≅ 30	≅ 130	-40~+200	<input type="checkbox"/>
PN1R3D25	1.3	12.0	0.059					<input type="checkbox"/>
PN1R5D25	1.5	11.5	0.065					<input type="checkbox"/>
PN2D25	2	11.5	0.071					<input type="checkbox"/>
PN2R2D25	2.2	11.0	0.080					<input type="checkbox"/>
PN2R5D25	2.5	9.5	0.090					<input type="checkbox"/>
PN3D25	3	9.0	0.121					<input type="checkbox"/>
PN3R3D25	3.3	9.0	0.130					<input type="checkbox"/>
PN4D25	4	8.5	0.132					<input type="checkbox"/>
PN4R7D25	4.7	8.5	0.145					<input type="checkbox"/>
PN5D25	5	7.5	0.179					<input type="checkbox"/>
PN6D25	6	7.0	0.195					<input type="checkbox"/>
PN6R8D25	6.8	6.5	0.233					<input type="checkbox"/>
PN7D25	7	6.0	0.281					<input type="checkbox"/>
PN8D25	8	5.5	0.347					<input type="checkbox"/>
PN10D25	10	5.0	0.414					<input type="checkbox"/>
PN12D25	12	4.5	0.395					<input type="checkbox"/>
PN13D25	13	4.5	0.428					<input type="checkbox"/>
PN15D25	15	4.0	0.543					<input type="checkbox"/>
PN16D25	16	3.5	0.651					<input type="checkbox"/>
PN18D25	18	3.0	0.658	<input type="checkbox"/>				
PN20D25	20	3.0	0.822	<input type="checkbox"/>				

Related Standards

Symbols	<input type="checkbox"/>	<input type="checkbox"/>	<input type="checkbox"/>	<input type="checkbox"/>	<input type="checkbox"/>	<input type="checkbox"/>	<input type="checkbox"/>
Approval							

Symbols	<input type="checkbox"/>	<input type="checkbox"/>
Approval		



**Reliability**

Characteristics	Standard	Test Conditions	Specifications
Robustness of terminations	IEC 60068-2-21	F = 10 N (d ≤ 0.8 mm) ,F = 20 N ( d = 1 mm)	No visible damage
Bending Strength of terminations	IEC 60068-2-21	F = 5 N (d ≤ 0.8 mm) ,F = 10 N ( d = 1 mm)	No visible damage
Solderability	IEC 60068-2-20	T = 245±5°C, d = 2±0.5s	Approximately ≥ 95%
Resistance to soldering heat	IEC 60068-2-20	T = 260±5°C, d = 10±1s	ΔR25/R25 ≤ ±20% No visible damage
High Temperature Storage	IEC60068-2-2	1000hrs, Tmax±5°C	ΔR25/R25 ≤ ±20% No visible damage
Damp heat (Steady state )	IEC 60068-2-78	T = 40±2°C, RH = 93(+2/-3)%, 1000 Hrs	ΔR25/R25 ≤ ±20% No visible damage
Rapid change of temperature	IEC 60068-2-14	N = 5 cycles, d = 30 min , θA = -40±3°C, θB = 85±2°C	ΔR25/R25 ≤ ±20% No visible damage
Life test	CNS5550	25±5°C, I <sub>max</sub> , 1000 Hrs	ΔR25/R25 ≤ ±20% No visible damage
Endurance	UL 1434	25±5°C, I <sub>max</sub> , C <sub>T</sub> 1min ON/ 5min OFF,1000 Cycles C <sub>T</sub> = Capacitance at 240 Vac	ΔR25/R25/R25 ≤ ±20% No visible damage
Insulation test	MIL-STD-202F	Sillicon: 1000Vdc ,1 min	≥500MΩ No visible damage

**Dimension of Component**

Straight lead type

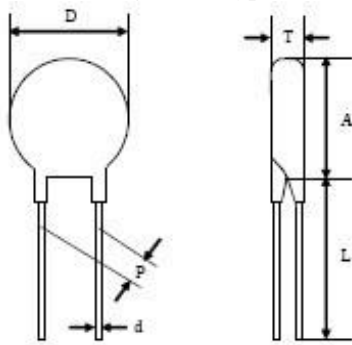

Dimension table

Unit: mm

Body Size	Dmax	P±1	d±0.05	Amax	Lmax	Tmax
Φ05	7.0	5.0	0.6	6.5	25.0	5.0
Φ07	9.5	5.0	0.6	9.5	25.0	5.0
Φ09	11.5	7.5	0.8	11.5	25.0	5.5
Φ11	13.0	7.5	0.8	13.0	25.0	5.5
Φ13	15.5	7.5	0.8	15.5	25.0	6.0
Φ15	17.5	7.5	0.8	17.5	25.0	6.0
Φ20	22.5	10.0	1.0	22.5	25.0	7.0
Φ25	27.5	10.0	1.0	29.0	25.0	8.0

Y kink lead type

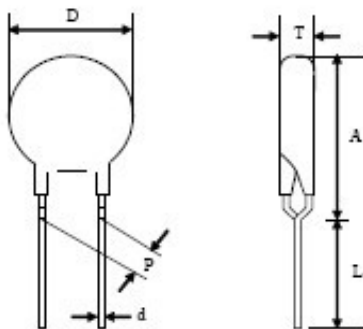

Dimension table

Unit: mm

Body Size	Dmax	P±1	d±0.05	Amax	Lmax	Tmax
Φ05	7.0	5.0	0.6	13.0	25.0	5.0
Φ07	9.5	5.0	0.6	15.0	25.0	5.0
Φ09	11.5	7.5	0.8	19.5	25.0	5.5
Φ11	13.0	7.5	0.8	21.5	25.0	5.5
Φ13	15.5	7.5	0.8	23.5	25.0	6.0
Φ15	17.5	7.5	0.8	25.5	25.0	6.0
Φ20	22.5	10.0	1.0	30.0	25.0	7.0
Φ25	27.5	10.0	1.0	35.0	25.0	8.0

Inner kink lead type

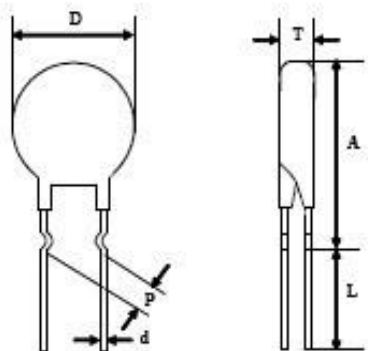

Dimension table

Unit: mm

Body Size	Dmax	P±1	d±0.05	Amax	Lmax	Tmax
Φ05	7.0	5.0	0.6	13.0	25.0	5.0
Φ07	9.5	5.0	0.6	15.0	25.0	5.0
Φ09	11.5	7.5	0.8	19.5	25.0	5.5
Φ11	13.0	7.5	0.8	21.5	25.0	5.5
Φ13	15.5	7.5	0.8	23.5	25.0	6.0
Φ15	17.5	7.5	0.8	25.5	25.0	6.0
Φ20	22.5	10.0	1.0	30.0	25.0	7.0
Φ25	27.5	10.0	1.0	35.0	25.0	8.0

**Taping Specification**

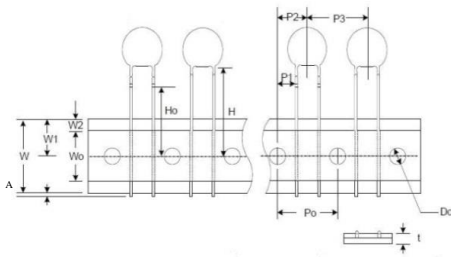

Figure A (P0=12.7) (P0=15.0)  
For I lead and W lead  $\Phi 5$  to  $\Phi 11$  type

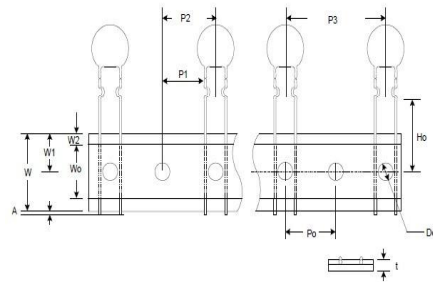

Figure B (P0=12.7)  
For I lead and W lead  $\Phi 13$  to  $\Phi 15$  type

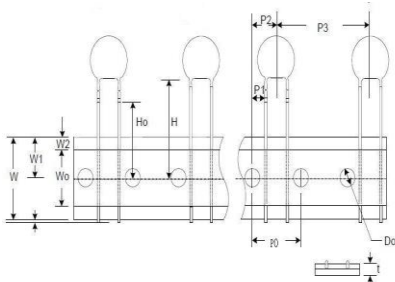

Figure C (P0=15.0)  
For I lead and W lead  $\Phi 13$  to  $\Phi 15$  type

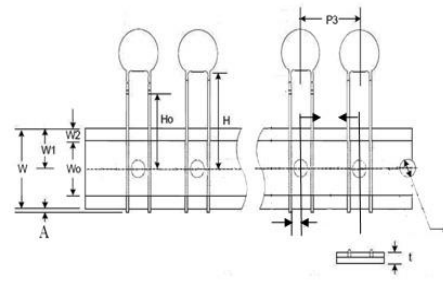
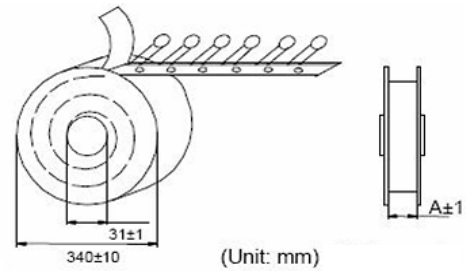

Figure D (P0=12.7)  
For I lead and W lead  $\Phi 9$  to  $\Phi 11$  type

Number	Size	P0	P1	P2	P3	H	H0	W0	W1	W2	W	A	D0	t	Figure
		$\pm 0.5$	$\pm 0.7$	$\pm 1.3$	$\pm 0.5$	+2/-0	$\pm 0.5$	Max	$\pm 0.5$	Max	$\pm 0.5$	Max	$\pm 0.2$	$\pm 0.2$	
A (P0=12.7)	$\Phi 5$	12.7	3.55	6.35	12.7	18	16	12	9	3	18	1	4	0.6	A
	$\Phi 7$	12.7	3.55	6.35	12.7	18	16	12	9	3	18	1	4	0.6	A
	$\Phi 9$	12.7	3.35	P3	12.7	18	16	12	9	3	18	1	4	0.6	D
	$\Phi 11$	12.7	3.35	P3	12.7	18	16	12	9	3	18	1	4	0.6	D
	$\Phi 13$	12.7	8.55	12.7	25.4	18	16	12	9	3	18	1	4	0.6	B
A (P0=15.0)	$\Phi 9$	15.0	3.35	7.5	15	18	16	12	9	3	18	1	4	0.6	A
	$\Phi 11$	15.0	3.35	7.5	15	18	16	12	9	3	18	1	4	0.6	A
	$\Phi 13$	15.0	3.35	7.5	30	18	16	12	9	3	18	1	4	0.6	C
	$\Phi 15$	15.0	3.25	7.5	30	18	16	12	9	3	18	1	4	0.6	C

**Reel Packing**

Body Size/mm	Quantity(pcs/bag)
Φ05	2500
Φ07	1500
Φ09	1500
Φ11	1500
Φ13	750
Φ15	750



Body Size	Φ 05	Φ 07~Φ 15
A	40mm	55mm

**Bulk Packing**

Body Size/mm	Quantity(pcs/bag)	Min Q'ty	Q'ty / InnE box	Q'ty / Carton
Φ05	200	2000	4000	20000
Φ07	200	2000	4000	20000
Φ09	200	1500	3000	15000
Φ11	200	1500	3000	15000
Φ13	100	1500	3000	15000
Φ15	100	1000	2000	8000
Φ20	50	500	1000	4000
Φ25	20	500	1000	4000

Part Number Code

