

**Description**

CNR D/V/P/H/N series metal oxide varistor are nonlinear resistors, consisting main of zinc oxide and several kinds of metal oxide additive. They are bilateral and symmetrical V-I characteristics curve and unparalleled large peak current capability are used for absorption of transient voltage, suppression of pulse noise and circuit voltage stabilization.

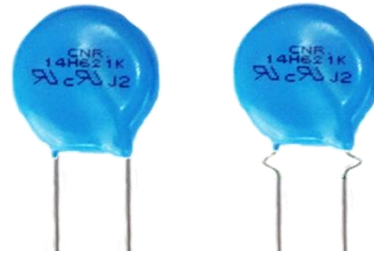



Agency Approvals		
Agency	Agency Approval	Certificate No.
	UL 1449 4 <sup>th</sup> & cUL	VZCA2.E316325 VZCA8.E316325
	IEC 61051-1	40044872
	IEC 61051-2	
	IEC 61051-2-2	
	IEC 60950-1:2013 for 10mm,14mm,18mm and 20mm only	
	-	-
	GB/T 10193	CQC16001148791
	GB/T 10194	CQC16001148792
	GB 4943.1	CQC16001148788
	GB 8898	CQC16001148786 CQC16001148789 CQC16001148841

Features
1. RoHS compliant
2. Halogen-free series are available
3. Body size: $\varnothing$ 05mm ~ $\varnothing$ 20mm
4. CNR-10H201K~10H112K ,CNR-14H201K~14H112K, CNR-18H201K~18H112K ,CNR-20H201K~20H112K , meet IEC 60950-1:2013 Annex Q requirement.
Applications
1. Power supply
2. Home appliance
3. Industrial equipment
4. Telecommunication or telephone system
5. Smart meter
6. Lighting products
7. Photovoltaic industry

Max. Rating		
	H-Seires	Units
AC Voltage Range (Vac)	130 to 680	V
DC Voltage Range(Vdc)	170 to 895	V
Peak Current for 8/20 $\mu$ S Current Wave	1200 to 20000	A
Energy Range For 10/1000 $\mu$ S Current Wave	13 to 950	J
Operation Ambient Temperature Range	-40 to +105	$^{\circ}$ C
Storage Tempersture Range	-40 to +125	$^{\circ}$ C
Varistor Voltage Range Vn(Vdc)	200 to 1100	V
Insulation Resistance	>1000	M $\Omega$
Typical Response Time	<25	ns

Device Ratings and Characteristics														
Part No.	Device Marking	Maximum Allowable Voltage		Varistor Voltage (@ 1mA)			Clamping Voltage @ Test Current (@8/20µs)		Maximum Energy (@10/1000µs) (J)	Maximum Peak Current (@8/20µs) (A)	Rated Power (W)	Typical Capacitance (@1KHz) (pF)	UL 1449 4th ,In @8/20us (KA)	Related Standards Symbol
		ACrms(V)	DC(V)	Vn(Vdc)	Min.	Max.	Vc(V)	Ip(A)						
CNR-05H201K	05H201K	130	170	200	180	220	340	10	13	1200	0.25	100	0.25	<input type="checkbox"/>
CNR-05H221K	05H221K	140	180	220	198	242	360	10	14	1200	0.25	100		<input type="checkbox"/>
CNR-05H241K	05H241K	150	200	240	216	264	395	10	15	1200	0.25	95		<input type="checkbox"/>
CNR-05H271K	05H271K	175	225	270	243	297	455	10	18	1200	0.25	95		<input type="checkbox"/>
CNR-05H301K	05H301K	195	250	300	270	330	500	10	19	1200	0.25	90		<input type="checkbox"/>
CNR-05H331K	05H331K	215	275	330	297	363	550	10	21	1200	0.25	90		<input type="checkbox"/>
CNR-05H361K	05H361K	230	300	360	324	396	595	10	23	1200	0.25	85		<input type="checkbox"/>
CNR-05H391K	05H391K	250	320	390	351	429	650	10	25	1200	0.25	80		<input type="checkbox"/>
CNR-05H431K	05H431K	275	350	430	387	473	710	10	28	1200	0.25	75		<input type="checkbox"/>
CNR-05H471K	05H471K	300	385	470	423	517	775	10	30	1200	0.25	70		<input type="checkbox"/>
CNR-05H511K	05H511K	320	420	510	459	561	845	10	30	1200	0.25	65		<input type="checkbox"/>
CNR-05H561K	05H561K	350	460	560	504	616	915	10	30	1200	0.25	60		<input type="checkbox"/>
CNR-05H621K	05H621K	395	510	620	558	682	1020	10	30	1200	0.25	55		<input type="checkbox"/>
CNR-05H681K	05H681K	420	560	680	612	748	1120	10	30	1200	0.25	50		<input type="checkbox"/>
CNR-05H751K	05H751K	465	615	750	675	825	1235	10	33	1200	0.25	40		<input type="checkbox"/>

**Related Standards**

Symbols	<input type="checkbox"/>
Approval	  



Device Ratings and Characteristics														
Part No.	Device Marking	Maximum Allowable Voltage		Varistor Voltage (@ 1mA)			Clamping Voltage @ Test Current (@ 8/20µs)		Maximum Energy (@ 10/1000µs) (J)	Maximum Peak Current (@ 8/20µs) (A)	Rated Power (W)	Typical Capacitance (@ 1KHz) (pF)	UL 1449 4th ,In @ 8/20us (KA)	Related Standards Symbol
		ACrms(V)	DC(V)	Vn(Vdc)	Min.	Max.	Vc(V)	Ip(A)						
CNR-07H201K	07H201K	130	170	200	180	220	340	25	26	2500	0.3	220	1	<input type="checkbox"/>
CNR-07H221K	07H221K	140	180	220	198	242	360	25	30	2500	0.3	210		<input type="checkbox"/>
CNR-07H241K	07H241K	150	200	240	216	264	395	25	33	2500	0.3	190		<input type="checkbox"/>
CNR-07H271K	07H271K	175	225	270	243	297	455	25	39	2500	0.3	165		<input type="checkbox"/>
CNR-07H301K	07H301K	195	250	300	270	330	500	25	42	2500	0.3	155		<input type="checkbox"/>
CNR-07H331K	07H331K	215	275	330	297	363	550	25	44	2500	0.3	145		<input type="checkbox"/>
CNR-07H361K	07H361K	230	300	360	324	396	595	25	50	2500	0.3	145		<input type="checkbox"/>
CNR-07H391K	07H391K	250	320	390	351	429	650	25	53	2500	0.3	145		<input type="checkbox"/>
CNR-07H431K	07H431K	275	350	430	387	473	710	25	60	2500	0.3	130		<input type="checkbox"/>
CNR-07H471K	07H471K	300	385	470	423	517	775	25	65	2500	0.3	110		<input type="checkbox"/>
CNR-07H511K	07H511K	320	420	510	459	561	845	25	70	2500	0.3	100		<input type="checkbox"/>
CNR-07H561K	07H561K	350	460	560	504	616	915	25	75	2500	0.3	100		<input type="checkbox"/>
CNR-07H621K	07H621K	395	510	620	558	682	1020	25	80	2500	0.3	100		<input type="checkbox"/>
CNR-07H681K	07H681K	420	560	680	612	748	1120	25	85	2500	0.3	90		<input type="checkbox"/>
CNR-07H751K	07H751K	465	615	750	675	825	1235	25	92	2500	0.3	90		<input type="checkbox"/>
CNR-07H781K	07H781K	485	640	780	702	858	1290	25	102	2500	0.3	90		<input type="checkbox"/>
CNR-07H821K	07H821K	510	670	820	738	902	1355	25	115	2500	0.3	80		<input type="checkbox"/>

**Related Standards**

Symbols	<input type="checkbox"/>
Approval	  



Device Ratings and Characteristics														
Part No.	Device Marking	Maximum Allowable Voltage		Varistor Voltage (@ 1mA)			Clamping Voltage @ Test Current (@ 8/20µs)		Maximum Energy (@ 10/1000µs) (J)	Maximum Peak Current (@ 8/20µs) (A)	Rated Power (W)	Typical Capacitance (@ 1KHz) (pF)	UL 1449 4th ,In @ 8/20us (KA)	Related Standards Symbol
		ACrms(V)	DC(V)	Vn(Vdc)	Min.	Max.	Vc(V)	Ip(A)						
CNR-10H201K	10H201K	130	170	200	180	220	340	50	52	4500	0.5	420	3	<input type="checkbox"/>
CNR-10H221K	10H221K	140	180	220	198	242	360	50	58	4500	0.5	390		<input type="checkbox"/>
CNR-10H241K	10H241K	150	200	240	216	264	395	50	64	4500	0.5	360		<input type="checkbox"/>
CNR-10H271K	10H271K	175	225	270	243	297	455	50	67	4500	0.5	330		<input type="checkbox"/>
CNR-10H301K	10H301K	195	250	300	270	330	500	50	70	4500	0.5	300		<input type="checkbox"/>
CNR-10H331K	10H331K	215	275	330	297	363	550	50	78	4500	0.5	270		<input type="checkbox"/>
CNR-10H361K	10H361K	230	300	360	324	396	595	50	84	4500	0.5	250		<input type="checkbox"/>
CNR-10H391K	10H391K	250	320	390	351	429	650	50	91	4500	0.5	230		<input type="checkbox"/>
CNR-10H431K	10H431K	275	350	430	387	473	710	50	99	4500	0.5	220		<input type="checkbox"/>
CNR-10H471K	10H471K	300	385	470	423	517	775	50	107	4500	0.5	200		<input type="checkbox"/>
CNR-10H511K	10H511K	320	420	510	459	561	845	50	117	4500	0.5	190		<input type="checkbox"/>
CNR-10H561K	10H561K	350	460	560	504	616	915	50	125	4500	0.5	180		<input type="checkbox"/>
CNR-10H621K	10H621K	395	510	620	558	682	1020	50	128	4500	0.5	160		<input type="checkbox"/>
CNR-10H681K	10H681K	420	560	680	612	748	1120	50	134	4500	0.5	140		<input type="checkbox"/>
CNR-10H751K	10H751K	465	615	750	675	825	1235	50	146	4500	0.5	130		<input type="checkbox"/>
CNR-10H781K	10H781K	485	640	780	702	858	1290	50	154	4500	0.5	120		<input type="checkbox"/>
CNR-10H821K	10H821K	510	670	820	738	902	1355	50	161	4500	0.5	110		<input type="checkbox"/>
CNR-10H911K	10H911K	550	745	910	819	1001	1500	50	168	4500	0.5	80		<input type="checkbox"/>
CNR-10H102K	10H102K	625	825	1000	900	1100	1650	50	182	4500	0.5	60		<input type="checkbox"/>
CNR-10H112K	10H112K	680	895	1100	990	1210	1815	50	196	4500	0.5	50		<input type="checkbox"/>

**Related Standards**

Symbols	<input type="checkbox"/>
Approval	  



Device Ratings and Characteristics														
Part No.	Device Marking	Maximum Allowable Voltage		Varistor Voltage (@ 1mA)			Clamping Voltage @ Test Current (@8/20µs)		Maximum Energy (@10/1000µs) (J)	Maximum Peak Current (@8/20µs) (A)	Rated Power (W)	Typical Capacitance (@1KHz) (pF)	UL 1449 4th ,In @8/20us (KA)	Related Standards Symbol
		ACrms(V)	DC(V)	Vn(Vdc)	Min.	Max.	Vc(V)	Ip(A)						
CNR-14H201K	14H201K	130	170	200	180	220	340	100	140	10000	1	860	3	<input type="checkbox"/>
CNR-14H221K	14H221K	140	180	220	198	242	360	100	155	10000	1	810		<input type="checkbox"/>
CNR-14H241K	14H241K	150	200	240	216	264	395	100	168	10000	1	860		<input type="checkbox"/>
CNR-14H271K	14H271K	175	225	270	243	297	455	100	190	10000	1	700		<input type="checkbox"/>
CNR-14H301K	14H301K	195	250	300	270	330	500	100	209	10000	1	640		<input type="checkbox"/>
CNR-14H331K	14H331K	215	275	330	297	363	550	100	228	10000	1	580		<input type="checkbox"/>
CNR-14H361K	14H361K	230	300	360	324	396	595	100	255	10000	1	530		<input type="checkbox"/>
CNR-14H391K	14H391K	250	320	390	351	429	650	100	275	10000	1	480		<input type="checkbox"/>
CNR-14H431K	14H431K	275	350	430	387	473	710	100	303	10000	1	430		<input type="checkbox"/>
CNR-14H471K	14H471K	300	385	470	423	517	775	100	350	10000	1	380		<input type="checkbox"/>
CNR-14H511K	14H511K	320	410	510	459	561	845	100	382	10000	1	350		<input type="checkbox"/>
CNR-14H561K	14H561K	350	460	560	504	616	915	100	382	10000	1	320		<input type="checkbox"/>
CNR-14H621K	14H621K	395	510	620	558	682	1020	100	382	7500	1	300		<input type="checkbox"/>
CNR-14H681K	14H681K	420	560	680	612	748	1120	100	382	7500	1	270		<input type="checkbox"/>
CNR-14H751K	14H751K	465	615	750	675	825	1235	100	420	7500	1	250		<input type="checkbox"/>
CNR-14H781K	14H781K	485	640	780	702	858	1290	100	460	7500	1	240		<input type="checkbox"/>
CNR-14H821K	14H821K	510	670	820	738	902	1355	100	485	7500	1	220		<input type="checkbox"/>
CNR-14H911K	14H911K	550	745	910	819	1001	1500	100	510	7500	1	180		<input type="checkbox"/>
CNR-14H102K	14H102K	625	825	1000	900	1100	1650	100	565	7500	1	150		<input type="checkbox"/>
CNR-14H112K	14H112K	680	895	1100	990	1210	1815	100	620	7500	1	110		<input type="checkbox"/>

**Related Standards**

Symbols	<input type="checkbox"/>
Approval	  

Device Ratings and Characteristics														
Part No.	Device Marking	Maximum Allowable Voltage		Varistor Voltage (@ 1mA)			Clamping Voltage @ Test Current (@ 8/20µs)		Maximum Energy (@ 10/1000µs) (J)	Maximum Peak Current (@ 8/20µs) (A)	Rated Power (W)	Typical Capacitance (@ 1KHz) (pF)	UL 1449 4th ,In @ 8/20us (KA)	Related Standards Symbol
		ACrms(V)	DC(V)	Vn(Vdc)	Min.	Max.	Vc(V)	Ip(A)						
CNR-18H201K	18H201K	130	170	200	180	220	340	150	175	15000	1	1700	5	⊙
CNR-18H221K	18H221K	140	180	220	198	242	360	150	185	15000	1	1600		⊙
CNR-18H241K	18H241K	150	200	240	216	264	395	150	198	15000	1	1500		⊙
CNR-18H271K	18H271K	175	225	270	243	297	455	150	220	15000	1	1300		⊙
CNR-18H301K	18H301K	195	250	300	270	330	500	150	245	15000	1	1200		⊙
CNR-18H331K	18H331K	215	275	330	297	363	550	150	268	15000	1	1100		⊙
CNR-18H361K	18H361K	230	300	360	324	396	595	150	315	15000	1	1100		⊙
CNR-18H391K	18H391K	250	320	390	351	429	650	150	350	15000	1	1100		⊙
CNR-18H431K	18H431K	275	350	430	387	473	710	150	380	15000	1	1000		⊙
CNR-18H471K	18H471K	300	385	470	423	517	775	150	405	15000	1	900		⊙
CNR-18H511K	18H511K	320	410	510	459	561	845	150	445	15000	1	800		⊙
CNR-18H561K	18H561K	350	460	560	504	616	915	150	475	15000	1	750		⊙
CNR-18H621K	18H621K	395	510	620	558	682	1020	150	490	15000	1	570		⊙
CNR-18H681K	18H681K	420	560	680	612	748	1120	150	500	15000	1	550		⊙
CNR-18H751K	18H751K	465	615	750	675	825	1235	150	525	15000	1	530		⊙
CNR-18H781K	18H781K	485	640	780	702	858	1290	150	535	15000	1	500		⊙
CNR-18H821K	18H821K	510	670	820	738	902	1355	150	545	15000	1	500		⊙
CNR-18H911K	18H911K	550	745	910	819	1001	1500	150	595	15000	1	480		⊙
CNR-18H102K	18H102K	625	825	1000	900	1100	1650	150	650	15000	1	460		⊙
CNR-18H112K	18H112K	680	895	1100	990	1210	1815	150	720	15000	1	400		⊙



**Related Standards**

Symbols	⊙	
Approval		



Device Ratings and Characteristics														
Part No.	Device Marking	Maximum Allowable Voltage		Varistor Voltage (@ 1mA)			Clamping Voltage @ Test Current (@ 8/20µs)		Maximum Energy (@ 10/1000µs) (J)	Maximum Peak Current (@ 8/20µs) (A)	Rated Power (W)	Typical Capacitance (@ 1KHz) (pF)	UL 1449 4th ,In @ 8/20us (KA)	Related Standards Symbol
		ACrms(V)	DC(V)	Vn(Vdc)	Min.	Max.	Vc(V)	Ip(A)						
CNR-20H201K	20H201K	130	170	200	180	220	340	200	200	20000	1	2125	5	<input type="checkbox"/>
CNR-20H221K	20H221K	140	180	220	198	242	360	200	215	20000	1	2000		<input type="checkbox"/>
CNR-20H241K	20H241K	150	200	240	216	264	395	200	235	20000	1	1875		<input type="checkbox"/>
CNR-20H271K	20H271K	175	225	270	243	297	455	200	275	20000	1	1625		<input type="checkbox"/>
CNR-20H301K	20H301K	195	250	300	270	330	500	200	295	20000	1	1500		<input type="checkbox"/>
CNR-20H331K	20H331K	215	275	330	297	363	550	200	320	20000	1	1375		<input type="checkbox"/>
CNR-20H361K	20H361K	230	300	360	324	396	595	200	350	20000	1	1375		<input type="checkbox"/>
CNR-20H391K	20H391K	250	320	390	351	429	650	200	385	20000	1	1375		<input type="checkbox"/>
CNR-20H431K	20H431K	275	350	430	387	473	710	200	425	20000	1	1250		<input type="checkbox"/>
CNR-20H471K	20H471K	300	385	470	423	517	775	200	450	20000	1	1125		<input type="checkbox"/>
CNR-20H511K	20H511K	320	410	510	459	561	845	200	500	20000	1	1000		<input type="checkbox"/>
CNR-20H561K	20H561K	350	460	560	504	616	915	200	520	20000	1	938		<input type="checkbox"/>
CNR-20H621K	20H621K	395	510	620	558	682	1020	200	590	15000	1	713		<input type="checkbox"/>
CNR-20H681K	20H681K	420	560	680	612	748	1120	200	650	15000	1	688		<input type="checkbox"/>
CNR-20H751K	20H751K	465	615	750	675	825	1235	200	725	15000	1	663		<input type="checkbox"/>
CNR-20H781K	20H781K	485	640	780	702	858	1290	200	725	15000	1	625		<input type="checkbox"/>
CNR-20H821K	20H821K	510	670	820	738	902	1355	200	750	15000	1	625		<input type="checkbox"/>
CNR-20H911K	20H911K	550	745	910	819	1001	1500	200	815	15000	1	600		<input type="checkbox"/>
CNR-20H102K	20H102K	625	825	1000	900	1100	1650	200	900	15000	1	575		<input type="checkbox"/>
CNR-20H112K	20H112K	680	895	1100	990	1210	1815	200	950	15000	1	500		<input type="checkbox"/>

Related Standards

Symbols	<input type="checkbox"/>
Approval	  

**Reliability (Test items comply with customer request)**

Item	Standard	Test Conditions / Methods	Specifications
Robustness of terminations	IEC 60068-2-21 Test Ua1	F = 10 N (d ≤ 0.8 mm), F = 20 N (d = 1 mm)	$\Delta V_{1mA}/V_{1mA} \leq \pm 10\%$ No visible damage
Solderability	IEC 60068-2-20 Test Ta (Method 1)	T = 235±5°C, d = 2±0.5s	Approximately ≥ 95%
Resistance to soldering heat	IEC 60068-2-20 Test Tb (Method 1A)	T = 260±5°C, d = 10±1s	$\Delta V_{1mA}/V_{1mA} \leq \pm 5\%$ No visible damage
Shock	IEC 60068-2-27 Test Ea	Pulse shape: half-sine. a = 490 m/s <sup>2</sup> , d = 11ms. N = 6 x 3 shocks	$\Delta V_{1mA}/V_{1mA} \leq \pm 5\%$ No visible damage
Vibration	IEC 60068-2-6 Test Fc (Method B4)	Frequency range: 10 Hz to 55 Hz, a = 0.75 mm or 98 m/s <sup>2</sup> (whichever is the less), d = 3x2 h	$\Delta V_{1mA}/V_{1mA} \leq \pm 5\%$ No visible damage
Needle flame test	IEC 60695-11-5	Severity: Vertical 10 s	Duration of burning: 5 s max.
Voltage under pulse condition	IEC 61051-2	At class current, 8/20µs	As specified in specification
Voltage proof	IEC 61051-2	Metal balls method (4.8.1.2) 2500 V, 60 s	No breakdown or flashover
Pulse current - 8/20 µs	IEC 61051-2	8/20 µs, 10 times, I peak=0.25*Imax	$\Delta V/V \leq \pm 10\%$ No visible damage
Pulse current - 10/1000 µs	IEC 61051-2	10/1000 µs, 10 times, Ipeak = 0.0075* Imax	$\Delta V_{1mA}/V_{1mA} \leq \pm 10\%$ No visible damage
Combination pulse	IEC 60950-1:2013 Annex Q	Additional test: 10 pulses (combination pulse 6KV/3KA), in one direction, 1 per min	$\Delta V_{1mA}/V_{1mA} \leq \pm 10\%$ No visible damage U ≤ 1.1 U <sub>initial</sub> Voltage proof: No breakdown or flashover
Rapid change of temperature	IEC 60068-2-14 Test Na	N = 5 cycles, d = 30 min, θA = -40±3°C, θB = 85±2°C	$\Delta V_{1mA}/V_{1mA} \leq \pm 10\%$ No visible damage
Climatic sequence	IEC 60068-2-2 Test Ba IEC 60068-2-30 Test Db IEC 60068-2-1 Test Aa IEC 60068-2-30 Test Db	Dry heat, Test Ba:16±2h, T = 85±2°C Damp heat, Test Db first cycle :24h, T = 55±2°C Cold, Test Aa :2h, T = -40±3°C Damp heat Test Ba remaining cycles:5 cycle	$\Delta V_{1mA}/V_{1mA} \leq \pm 10\%$ No visible damage R <sub>ISO</sub> ≥ 100MΩ Voltage proof: No breakdown or flashover
Endurance at upper category temperature	IEC 61051-1 (4.21)	T: max temperature as specified, Duration: 1000 h, Voltage: max. a.c. voltage	$\Delta V/V \leq \pm 10\%$ No visible damage R <sub>ISO</sub> ≥ 1000MΩ U ≤ 1,1 U <sub>initial</sub>



**Reliability**

Item	Standard	Test Conditions / Methods	Specifications
Damp heat (Steady state)	IEC 60068-2-78 Test Ca	T = 40±2°C, RH = 93(+2/-3)%, 56d , 4 specimens:No voltage applied , Other 4 specimens:Applied voltage: 10% of the max. d.c. voltage	$\Delta V_{I_{max}}/V_{I_{max}} \leq \pm 10\%$ $R_{ISO} \geq 100M\Omega$
Maximum Peak Current	Specification Standard	I <sub>max</sub> , 8/20 μs, 1 time	$\Delta V_{I_{max}}/V_{I_{max}} \leq \pm 10\%$ No visible damage
Nominal Discharge Current Test	UL1449 4th	I <sub>n</sub> , 8/20 μs, 15 times, Interval 60s.	$\Delta V/V \leq \pm 10\%$ No visible damage
Varistor Voltage Temp. Coefficient	Specification Standard	$\frac{V_{I_{mA}} \text{ at } 85^{\circ}\text{C} - V_{I_{mA}} \text{ at } 25^{\circ}\text{C}}{V_{I_{mA}} \text{ at } 25^{\circ}\text{C}} \times \frac{1}{60} \times 100(\%/^{\circ}\text{C})$	-0.05 ≤ TC ≤ 0.05(%/°C)
High Temperature Storage	IEC60068-2-2	1000h, T = 125±2°C	$\Delta V/V \leq \pm 5\%$ No visible damage
Max. Energy	Specification Standard	10/1000 μs, 1 time, Max. Energy	$\Delta V/V \leq \pm 10\%$ No visible damage
Operating duty cycle test *	UL 1449	6 kV/3 kA combination wave surges, phase angle of 90 (+0, -15) degrees, positive polarity 8 times, negative polarity 7 times, interval of 60s.	$\Delta V/V \leq \pm 10\%$ No visible damage
Surge Immunity Test *	IEC 61000-4-5	4kV/2kA combination wave surges, phase angle of 90 (+0, -15) degrees, positive polarity 20times, negative polarity 20 times, interval of 60s.	$\Delta V/V \leq \pm 10\%$ No visible damage

\* (According to customer requirements to meet the test items)

Impulse Life Time Rating Curves

CNR-05H201K to CNR-05H751K

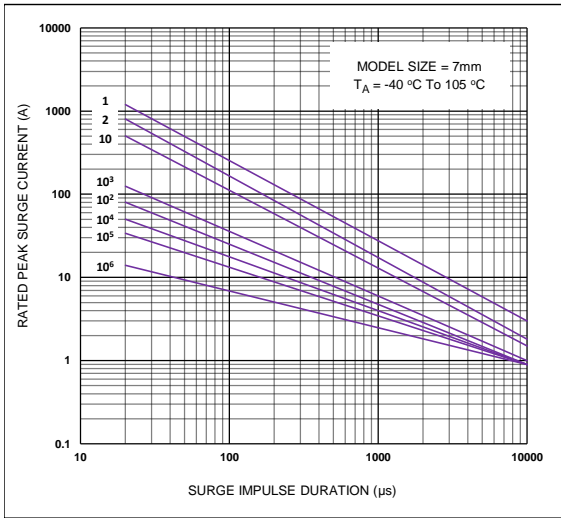

CNR-07H201K to CNR-07H821K

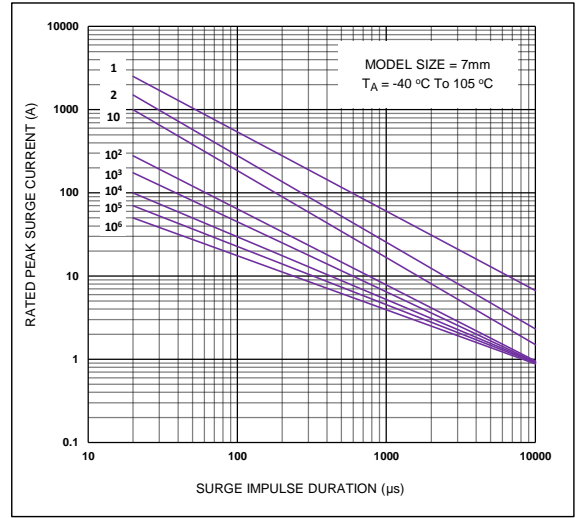

CNR-10H201K to CNR-10H112K

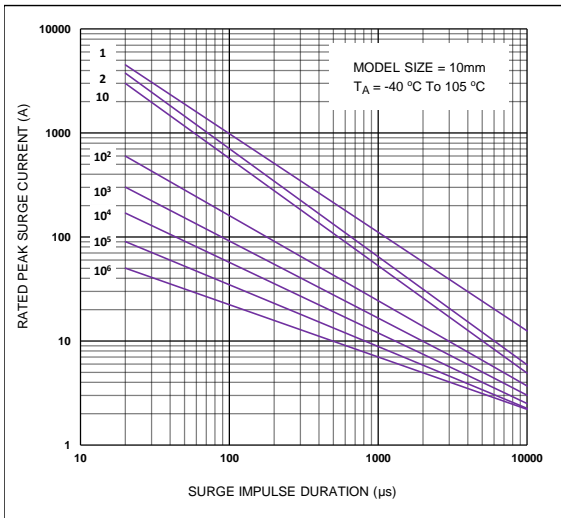

CNR-14H201K to CNR-14H561K

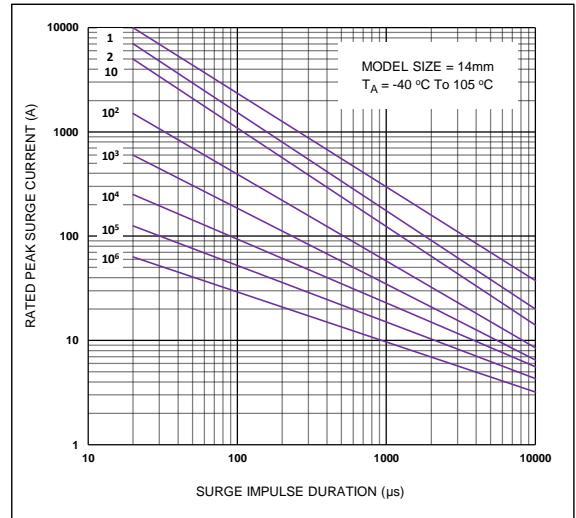

Impulse Life Time Rating Curves

CNR-14H621K to CNR-14H112K

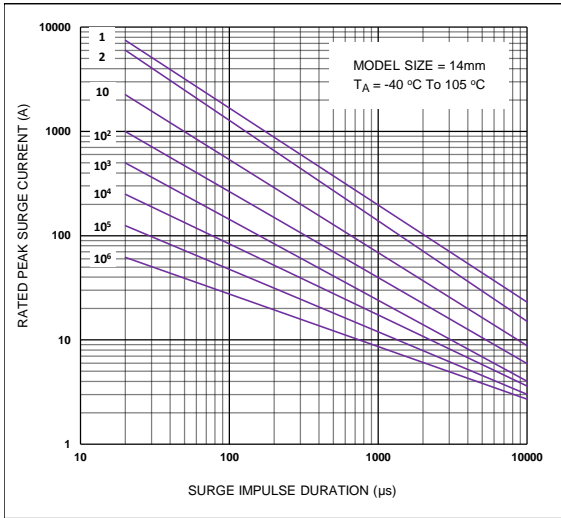

CNR-18H201K to CNR-18H112K

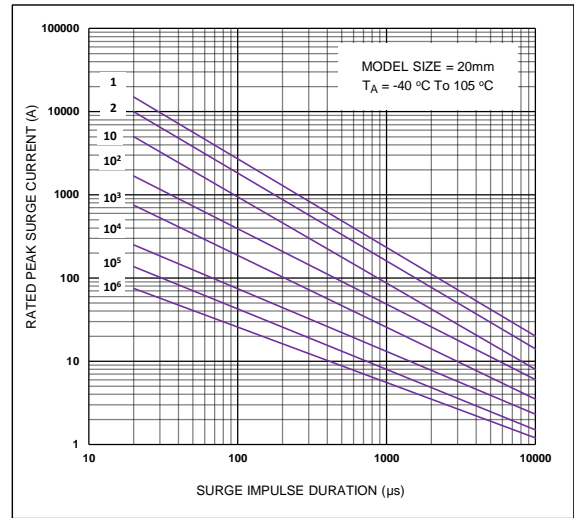

CNR-20H201K to CNR-20H561K

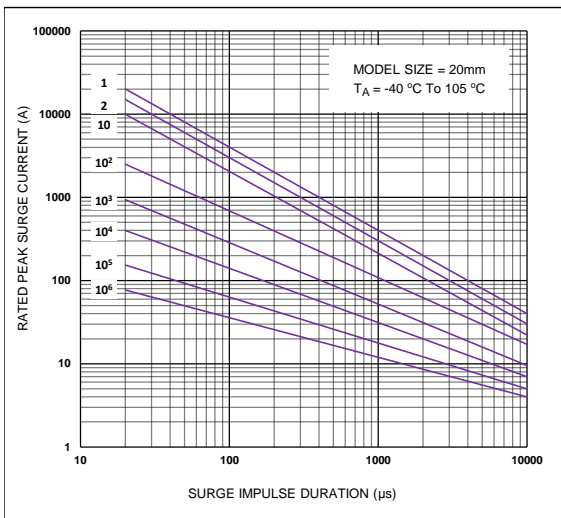

CNR-20H621K to CNR-20H112K

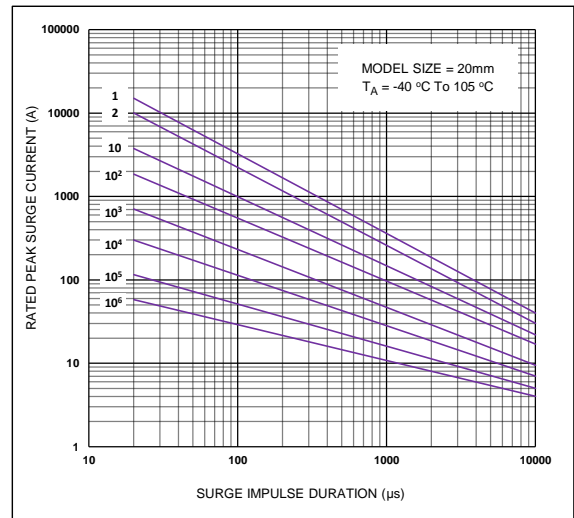



CNR-05H201K to CNR-05H751K V-I Curves

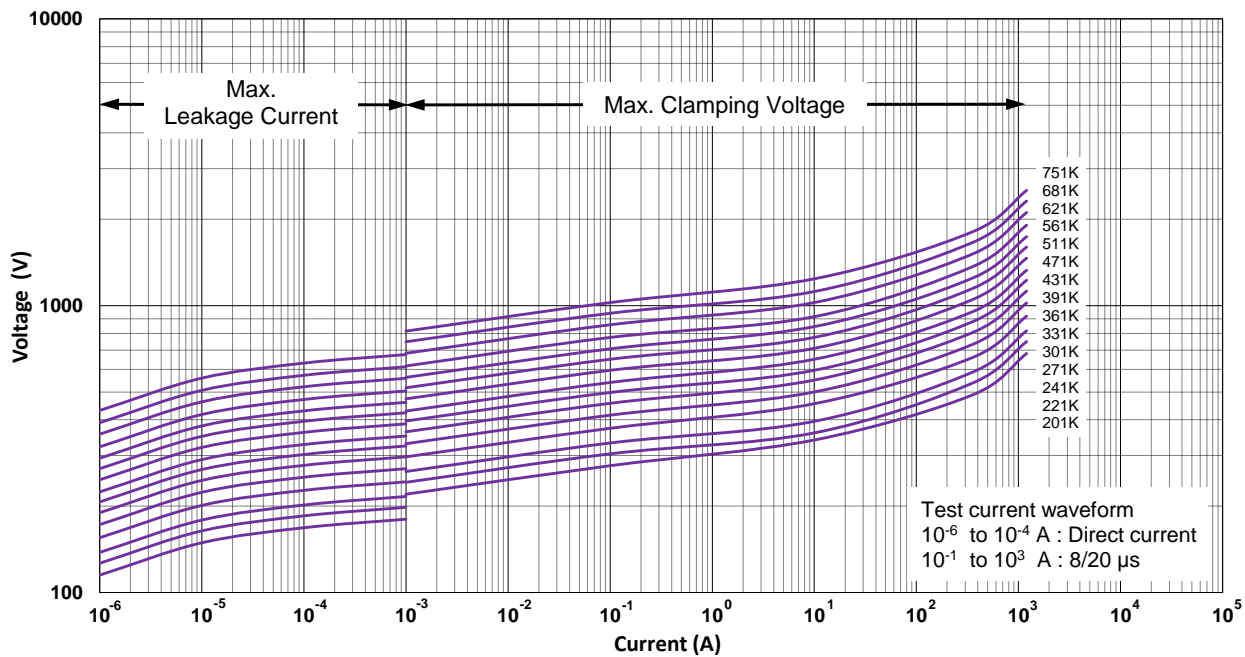

CNR-07H201K to CNR-07H821K V-I Curves

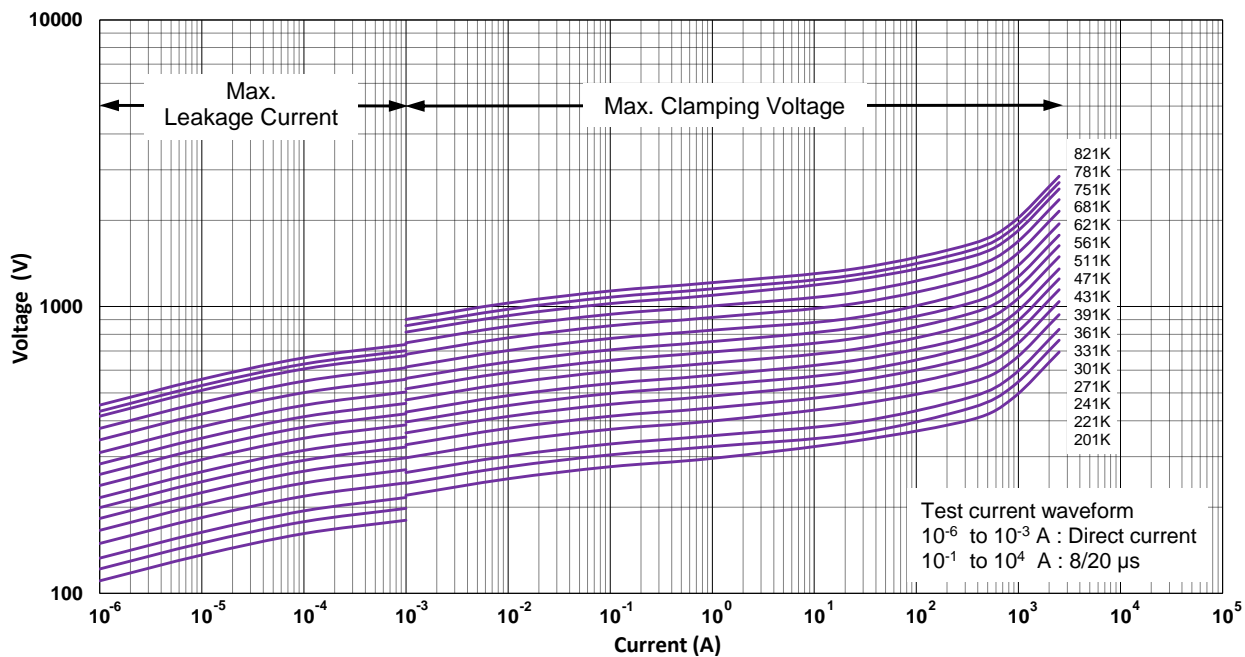



CNR-10H201K to CNR-10H561K V-I Curves

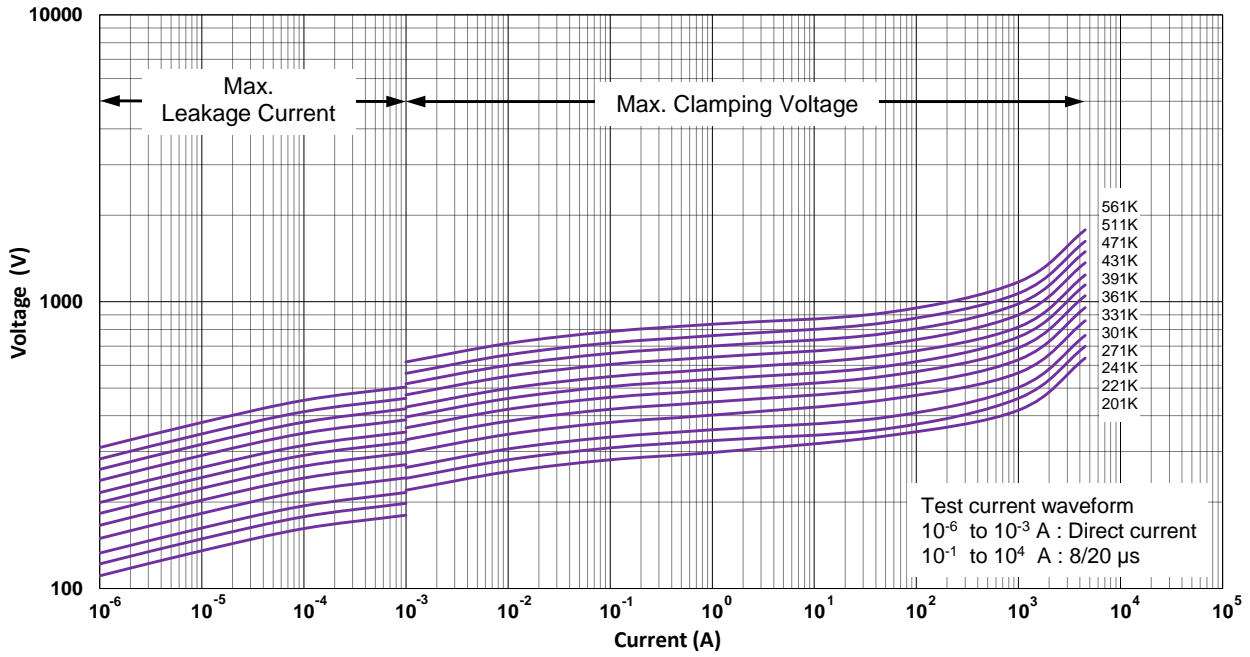

CNR-10H621K to CNR-10H112K V-I Curves

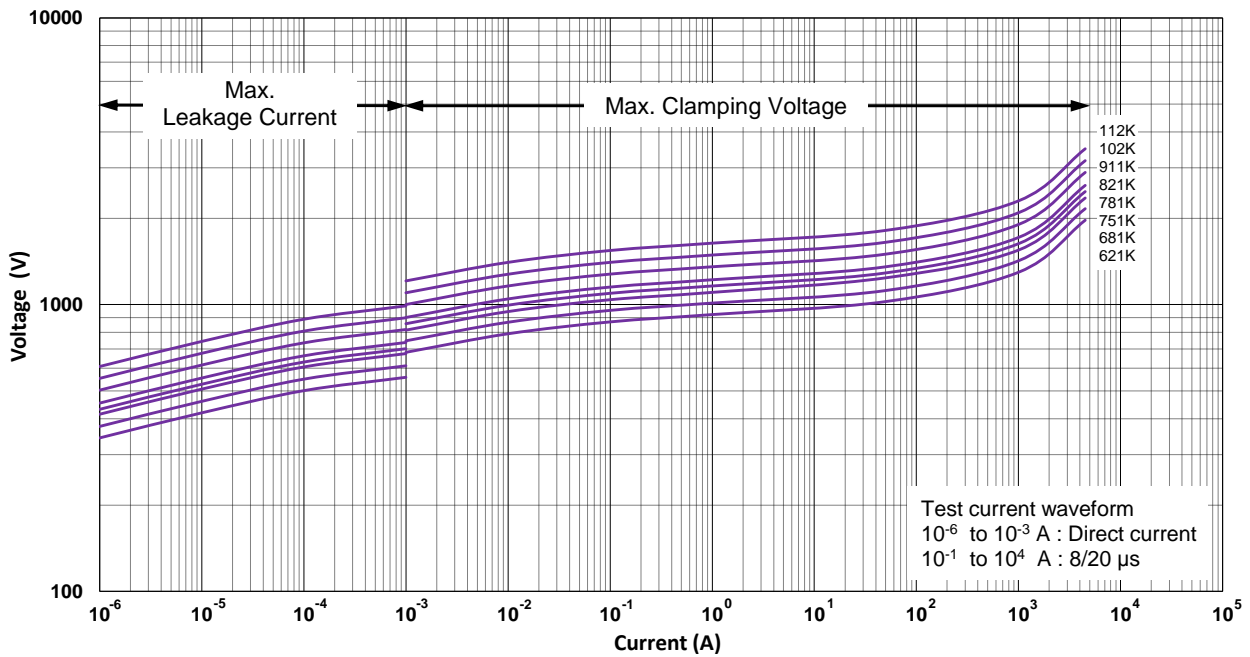



CNR-14H201K to CNR-14H561K V-I Curves

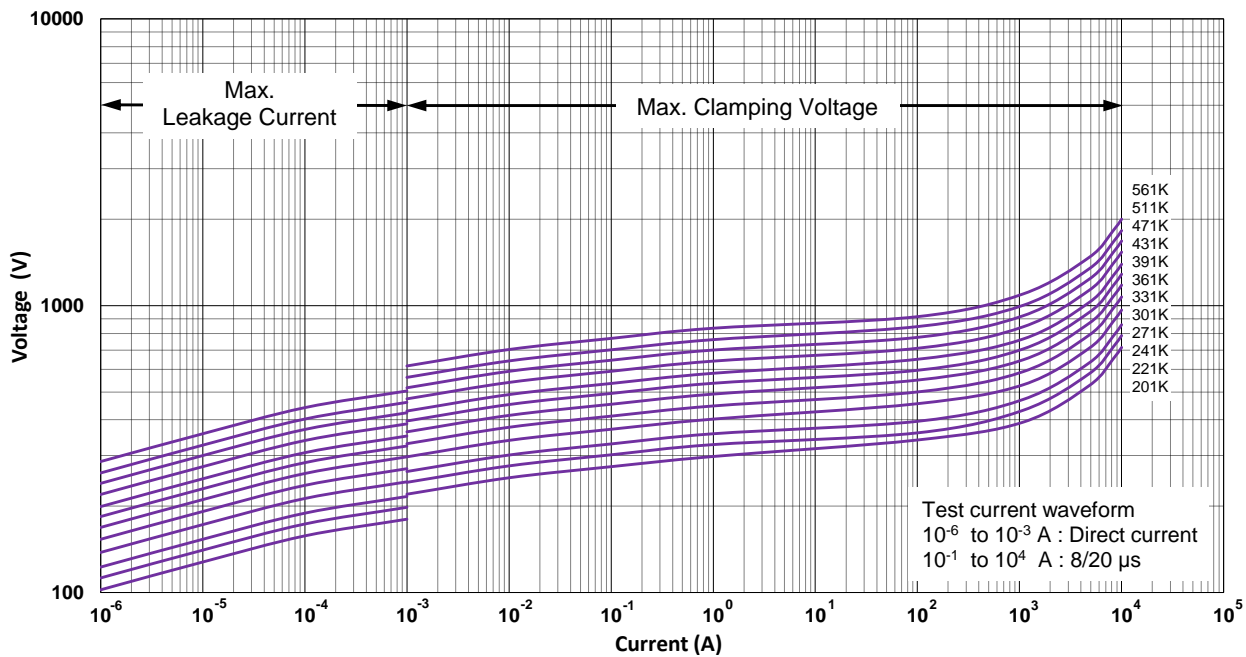

CNR-14H621K to CNR-14H112K V-I Curves

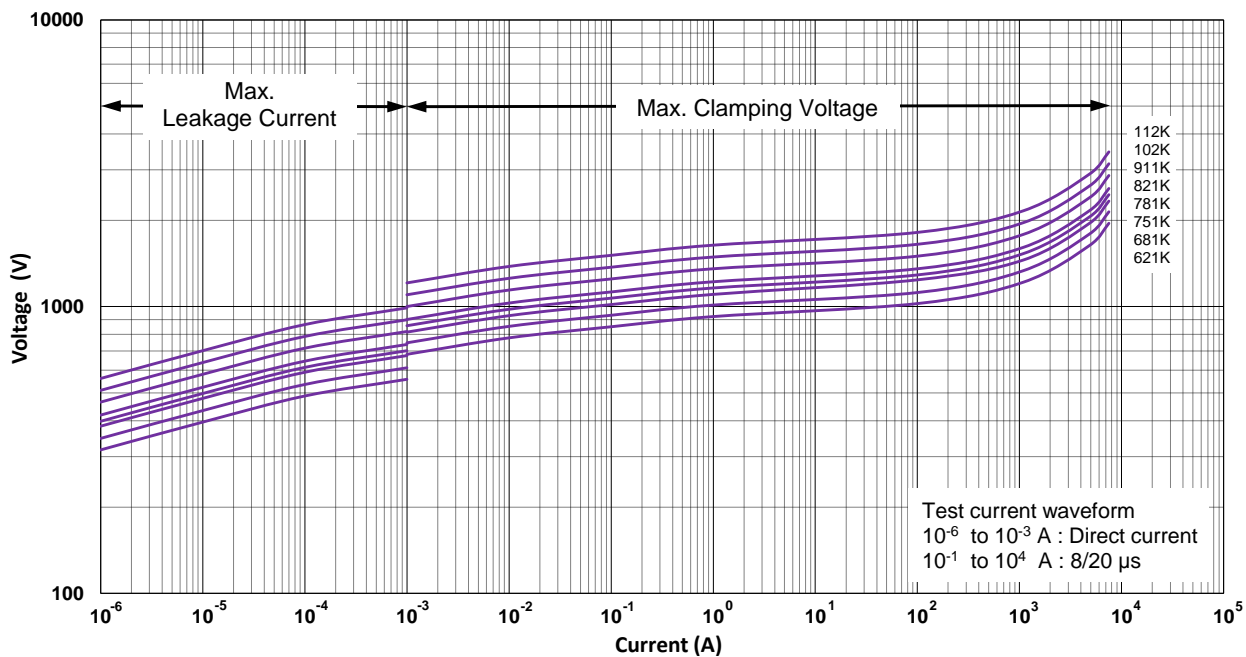



CNR-18H201K to CNR-18H112K V-I Curves

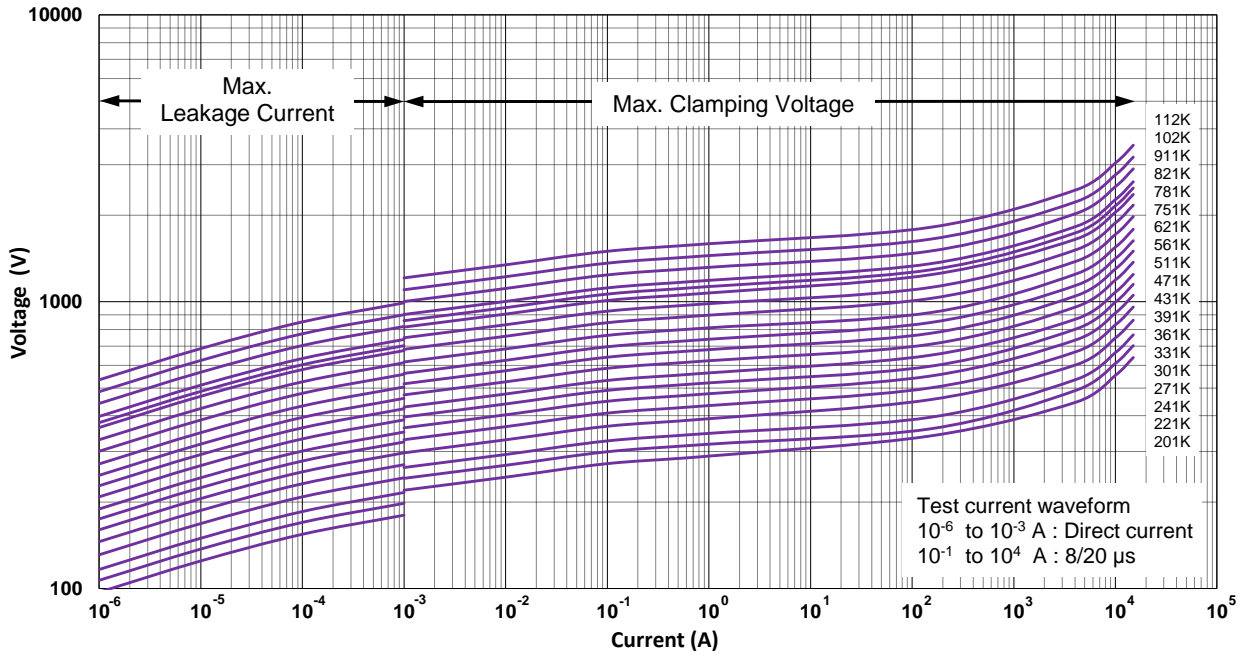

CNR-20H201K to CNR-20H561K V-I Curves

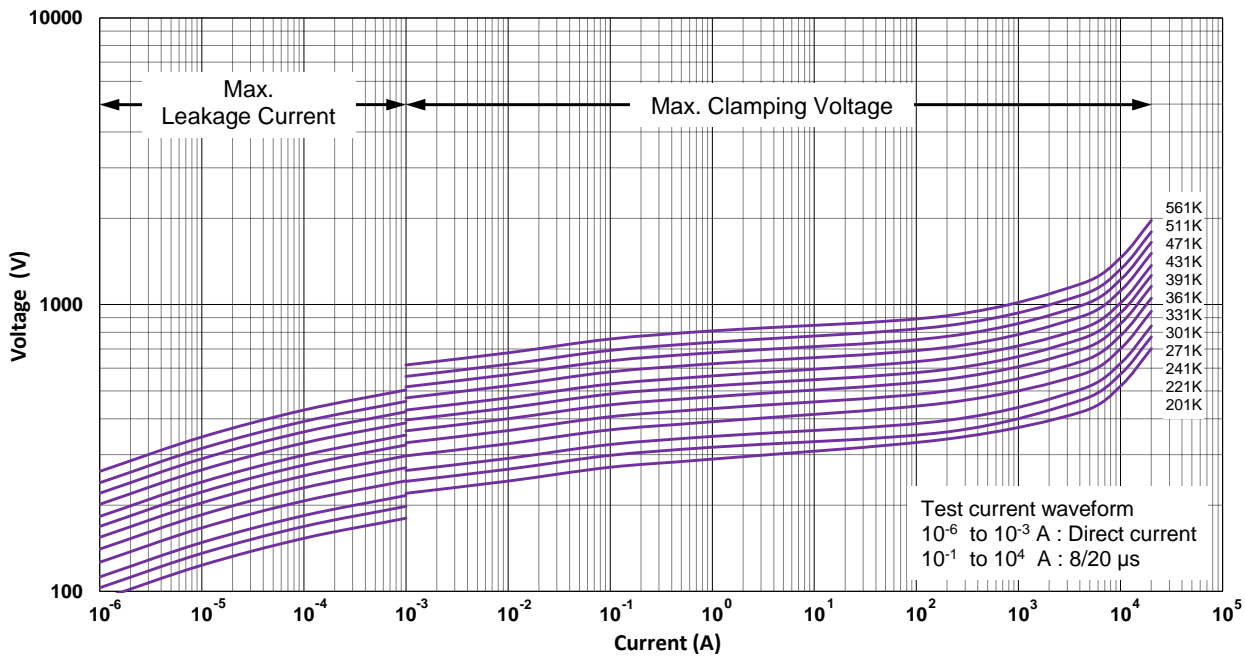

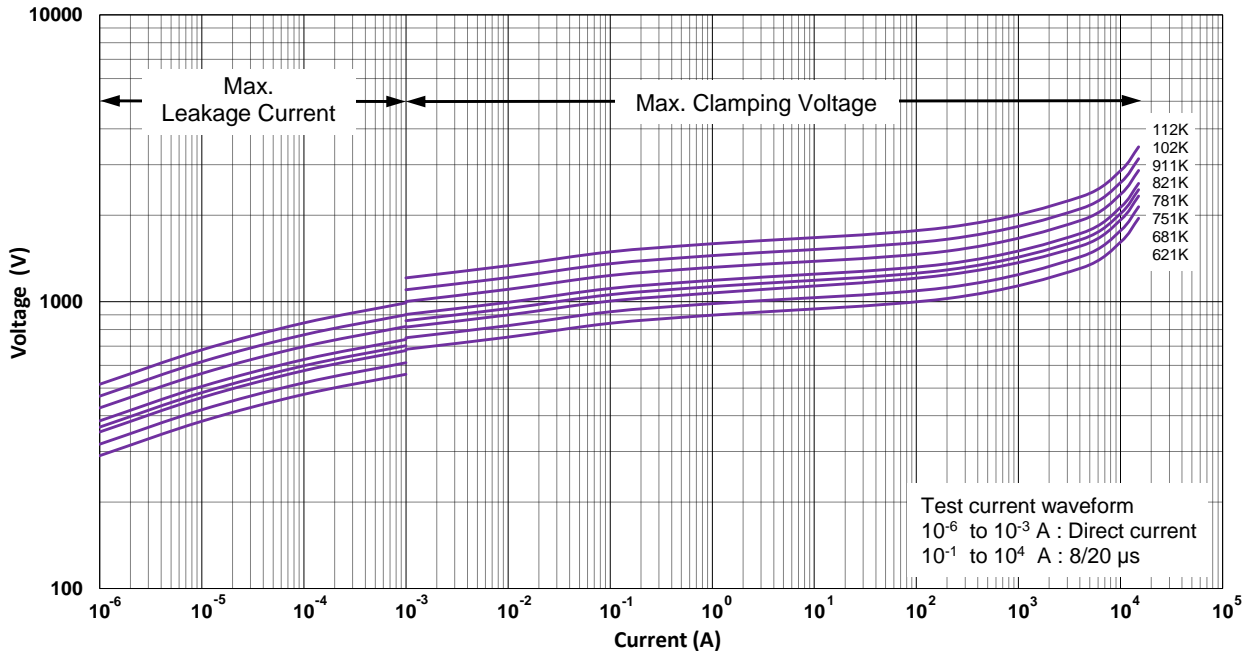



**Power Derating Curve**

Should transients occur in rapid succession, the average power dissipation is the energy (watt-seconds) per pulse times the number of pulses per second. The power so developed must be with the specifications shown on the Device Ratings and Specifications Table for the specific device. The operating values of a MOV need to be derated at high temperatures as shown above. Because varistors only dissipate a relatively small amount of average power they are not suitable for repetitive applications that involve substantial amounts of average power dissipation.

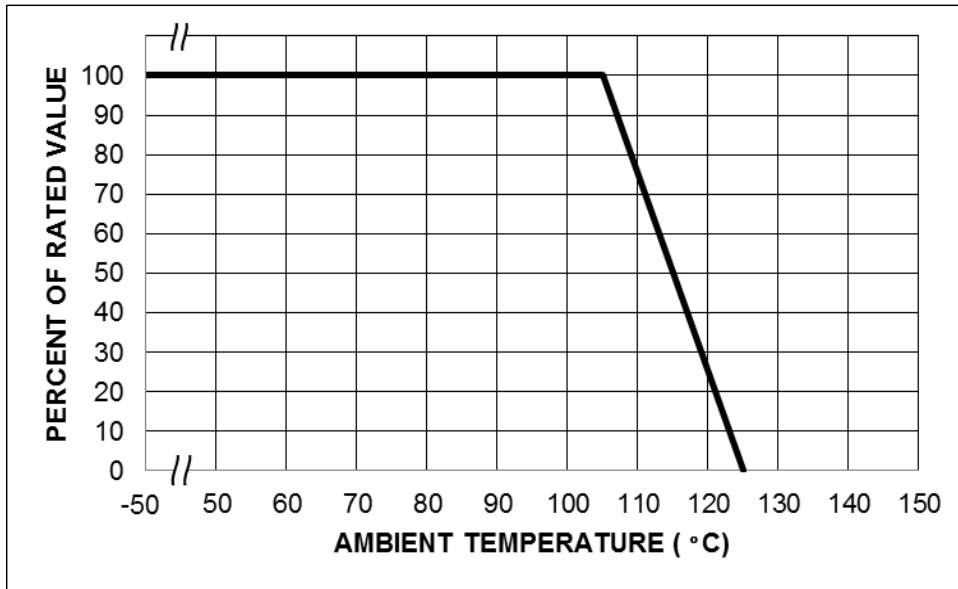

**Surge Current Standard Waveform**

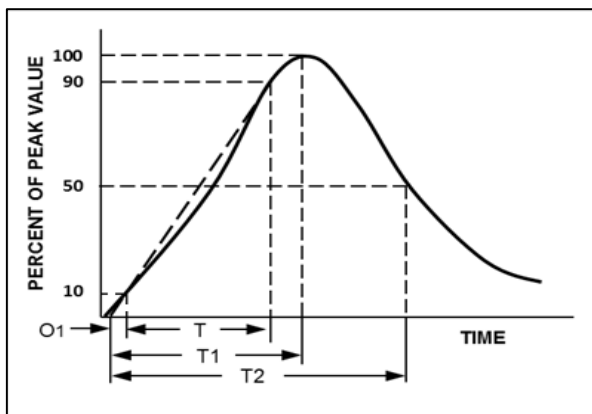

O1 = Virtual Origin of Wave  
 T = Time from 10% to 90% of Peak  
 T1 = Rise Time = 1.25 x T  
 T2 = Decay Time  
 Example - For an 8/20  $\mu$ s Current Waveform:  
 8 $\mu$ s = T1 = Rise Time  
 20 $\mu$ s = T2 = Decay Time

Product Dimensions

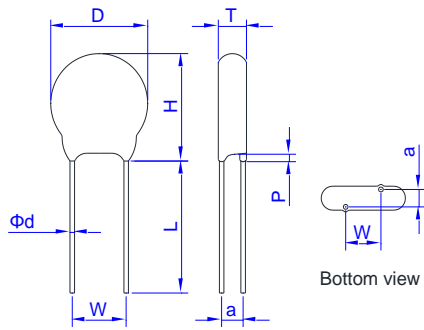

Fig 1. Straight Lead

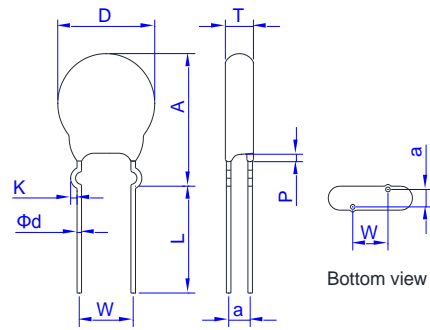

Fig 2. Outside Kink Lead

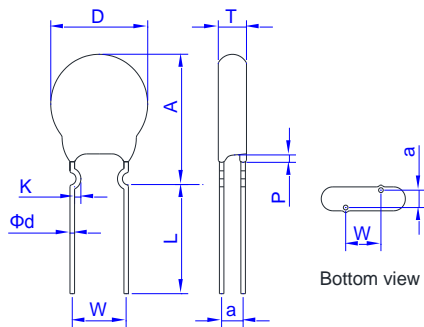

Fig 3. Inside Kink Lead

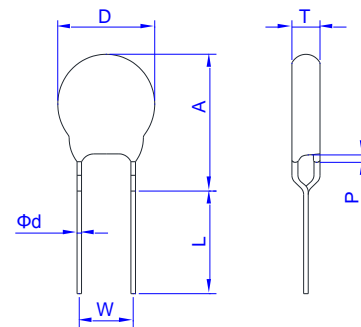

Fig 4. In Line Kink Lead

Dimension Table

Unit:mm

Symbol	Model	05H		07H		10H		14H		18H		20H	
		Min.	Max.	Min.	Max.	Min.	Max.	Min.	Max.	Min.	Max.	Min.	Max.
D		5.5	7.5	7.5	9.0	10.5	14.0	13.5	17.5	18.5	23.0	19.5	25.0
H		-	10.0	-	12.0	-	17.0	-	20.5	-	26.0	-	28.0
W		4.0	6.0	4.0	6.0	6.5	8.5	6.5	8.5	6.5	8.5	9.0	11.0
Φd		0.55	0.65	0.55	0.65	0.75	0.85	0.75	0.85	0.75	0.85	0.95	1.05
P(max.)		3.0											
L(min)		25.0											
K(Kink Lead)		0.8	1.6	0.8	1.6	1.0	1.8	1.0	1.8	1.0	1.8	1.0	1.8
A(max.)	180K-271K	-	13.0	-	15.0	-	19.5	-	22.5	-	26.5	-	30.0
	>271K	-	13.0	-	15.0	-	20.5	-	23.5	-	27.0	-	31.0
T		See Tmax table											

\* Short Cut Lead type TTXX the lead length (L) can 3.0~15mm (except 20H dia <10mm), see Ordering Note.

\* \* a value see T max. table

T max. Table								Unit:mm							
Model	05H	07H	10H	14H	18H	20H	a(±1.0)	Model	05H	07H	10H	14H	18H	20H	a(±1.0)
201K	3.9	4.0	4.5	4.6	4.6	5.1	2.0	511K	5.6	5.7	6.1	6.2	6.2	6.7	3.7
221K	4.0	4.1	4.6	4.7	4.7	5.2	2.1	561K	5.8	5.9	6.3	6.4	6.4	6.9	3.9
241K	4.1	4.2	4.7	4.8	4.8	5.3	2.2	621K	6.2	6.3	6.5	6.6	6.6	7.2	4.3
271K	4.4	4.5	4.8	4.9	4.9	5.4	2.3	681K	6.3	6.4	6.6	6.7	6.7	7.3	4.7
301K	4.6	4.7	4.9	5.0	5.0	5.5	2.5	751K	6.5	6.6	6.8	6.9	6.9	7.5	5.1
331K	4.7	4.8	5.1	5.2	5.2	5.8	2.7	781K	-	6.9	7.2	7.3	7.3	7.9	5.2
361K	4.8	4.9	5.4	5.5	5.5	6.0	2.8	821K	-	7.2	7.4	7.5	7.5	8.1	5.4
391K	4.9	5.0	5.5	5.6	5.6	6.1	3.0	911K	-	-	7.5	7.6	7.6	8.2	5.9
431K	5.2	5.3	5.7	5.8	5.8	6.4	3.2	102K	-	-	8.0	8.1	8.1	8.7	6.5
471K	5.4	5.5	5.9	6.0	6.0	6.6	3.4	112K	-	-	8.9	9.0	9.0	9.3	7.1

**Tape and Reel Specifications**

● Radial devices on tape are supplied with straight leads, kinked leads or in -line leads

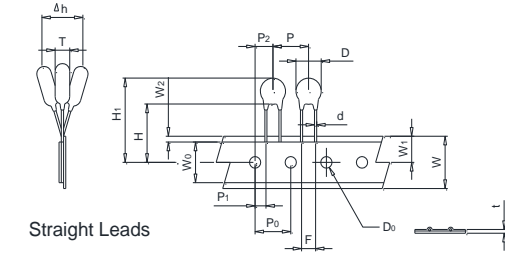

Figure: A

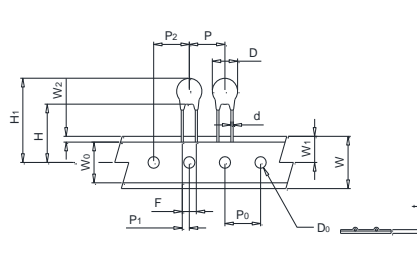

Figure: B

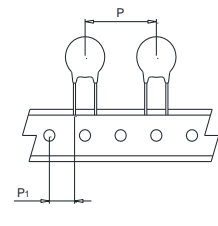

Figure: C

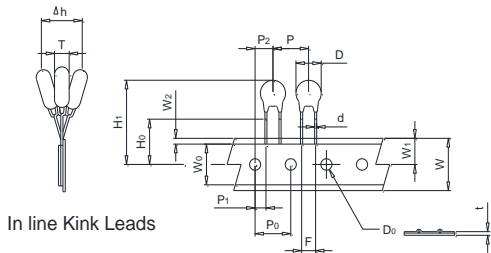

Figure: D

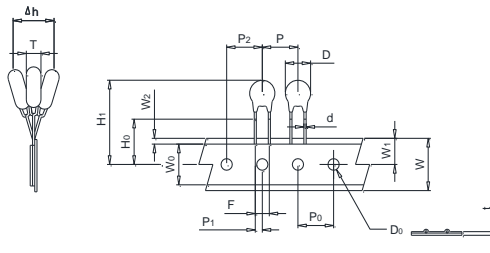

Figure: E

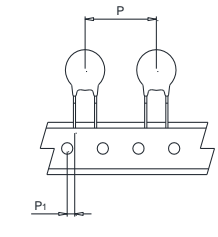

Figure: F

Symbol	Description	Model Size					
		5H	7H	10H	14H	18H	20H
P	Pitch of Component	12.7±1.0	12.7±1.0	12.7±1.0	15.0±1.0	25.4±1.0	30.0±1.0
P <sub>0</sub>	Feed Hole Pitch	12.7±0.2	12.7±0.2	12.7±0.2	15.0±0.2	25.4±0.2	30.0±0.2
P <sub>1</sub>	Feed Hole Center to Pitch	3.85±0.7	3.85±0.7	8.95±0.7	3.75±0.7	8.95±0.7	3.75±0.7
P <sub>2</sub>	Hole Center to Component Center	6.35±0.7	6.35±0.7	12.7±0.7	7.5±0.7	12.7±0.7	7.5±0.7
F	Lead to Lead Distance	5.0±0.8	5.0±0.8	7.5±0.8	7.5±0.8	7.5±0.8	7.5±0.8
△h	Component Alignment	2.0max	2.0max	2.0max	2.0max	2.0max	2.0max
W	Tape Width	18.0+1.0	18.0+1.0	18.0+1.0	18.0+1.0	18.0+1.0	18.0+1.0
		18.0-0.5	18.0-0.5	18.0-0.5	18.0-0.5	18.0-0.5	18.0-0.5
W <sub>0</sub>	Hold Down Tape Width	5.0 Min.	5.0 Min.	5.0 Min.	5.0 Min.	5.0 Min.	5.0 Min.
W <sub>1</sub>	Hole Position	9.0+0.75	9.0+0.75	9.0+0.75	9.0+0.75	9.0+0.75	9.0+0.75
		9.0-0.5	9.0-0.5	9.0-0.5	9.0-0.5	9.0-0.5	9.0-0.5
W <sub>2</sub>	Hold Down Tape Position	3.0 Max	3.0 Max	3.0 Max	3.0 Max	3.0 Max	3.0 Max
H	Height from Tape Center to Component Base	18.0+2.0	18.0+2.0	18.0+2.0	18.0+2.0	18.0+2.0	18.0+2.0
		18.0-0.0	18.0-0.0	18.0-0.0	18.0-0.0	18.0-0.0	18.0-0.0
H <sub>0</sub>	Seating Plane Height	16.0±0.5	16.0±0.5	16.0±0.5	16.0±0.5	16.0±0.5	16.0±0.5
H <sub>1</sub>	Component Height	29.0 Max.	32.0 Max.	36.0 Max.	36.0 Max.	40.0 Max.	40.0 Max.
D <sub>0</sub>	Feed Hole Diameter	4.0±0.2	4.0±0.2	4.0±0.2	4.0±0.2	4.0±0.2	4.0±0.2
t	Total Tape Thickness	0.7±0.2	0.7±0.2	0.7±0.2	0.7±0.2	0.7±0.2	0.7±0.2
L	Leagth Clipped Lead	11.0 Max	11.0 Max	11.0 Max	11.0 Max	11.0 Max	11.0 Max
Figure		A, D	A, D	B, E	A, D	C	F

**Tape and Reel Specifications**

● Radial devices on tape are supplied with straight leads, kinked leads or in -line leads

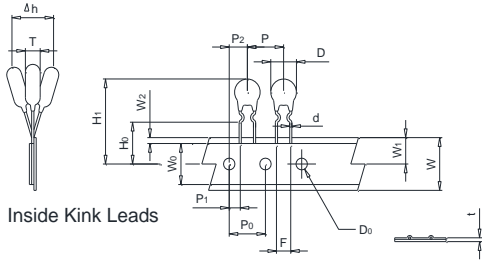

Figure: A

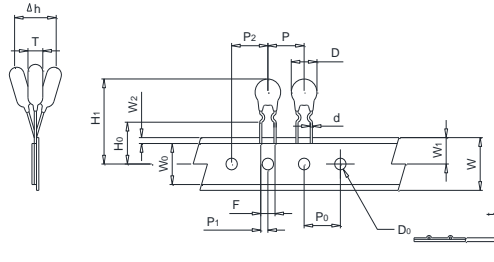

Figure: B

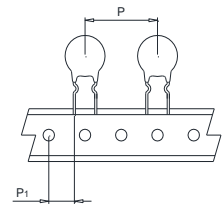

Figure: C

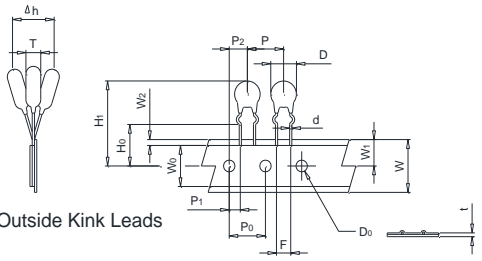

Figure: D

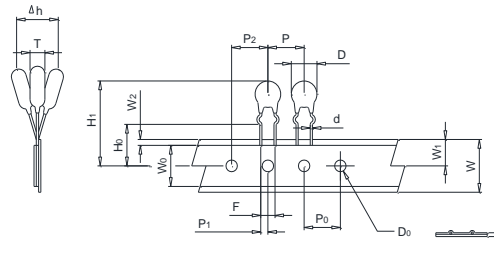

Figure: E

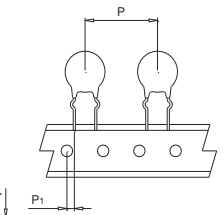

Figure: F

Symbol	Description	Model Size					
		5H	7H	10H	14H	18H	20H
P	Pitch of Component	12.7±1.0	12.7±1.0	12.7±1.0	15.0±1.0	25.4±1.0	30.0±1.0
P <sub>0</sub>	Feed Hole Pitch	12.7±0.2	12.7±0.2	12.7±0.2	15.0±0.2	25.4±0.2	30.0±0.2
P <sub>1</sub>	Feed Hole Center to Pitch	3.85±0.7	3.85±0.7	8.95±0.7	3.75±0.7	8.95±0.7	3.75±0.7
P <sub>2</sub>	Hole Center to Component Center	6.35±0.7	6.35±0.7	12.7±0.7	7.5±0.7	12.7±0.7	7.5±0.7
F	Lead to Lead Distance	5.0±0.8	5.0±0.8	7.5±0.8	7.5±0.8	7.5±0.8	7.5±0.8
△h	Component Alignment	2.0max	2.0max	2.0max	2.0max	2.0max	2.0max
W	Tape Width	18.0+1.0	18.0+1.0	18.0+1.0	18.0+1.0	18.0+1.0	18.0+1.0
		18.0-0.5	18.0-0.5	18.0-0.5	18.0-0.5	18.0-0.5	18.0-0.5
W <sub>0</sub>	Hold Down Tape Width	5.0 Min.	5.0 Min.	5.0 Min.	5.0 Min.	5.0 Min.	5.0 Min.
W <sub>1</sub>	Hole Position	9.0+0.75	9.0+0.75	9.0+0.75	9.0+0.75	9.0+0.75	9.0+0.75
		9.0-0.5	9.0-0.5	9.0-0.5	9.0-0.5	9.0-0.5	9.0-0.5
W <sub>2</sub>	Hold Down Tape Position	3.0 Max	3.0 Max	3.0 Max	3.0 Max	3.0 Max	3.0 Max
H	Height from Tape Center to Component Base	18.0+2.0	18.0+2.0	18.0+2.0	18.0+2.0	18.0+2.0	18.0+2.0
		18.0-0.0	18.0-0.0	18.0-0.0	18.0-0.0	18.0-0.0	18.0-0.0
H <sub>0</sub>	Seating Plane Height	16.0±0.5	16.0±0.5	16.0±0.5	16.0±0.5	16.0±0.5	16.0±0.5
H <sub>1</sub>	Component Height	29.0 Max.	32.0 Max.	36.0 Max.	36.0 Max.	40.0 Max.	40.0 Max.
D <sub>0</sub>	Feed Hole Diameter	4.0±0.2	4.0±0.2	4.0±0.2	4.0±0.2	4.0±0.2	4.0±0.2
t	Total Tape Thickness	0.7±0.2	0.7±0.2	0.7±0.2	0.7±0.2	0.7±0.2	0.7±0.2
L	Leagth Clipped Lead	11.0 Max	11.0 Max	11.0 Max	11.0 Max	11.0 Max	11.0 Max
Figure		A, D	A, D	B, E	A, D	C	F

**Packing information**

Bulk packing

Series	Straight Lead Type Quantity(pcs/bag)	Cut Lead Type Quantity(pcs/bag)	Kink Type Quantity(pcs/bag)
CNR-05H	1000	1000	1000
CNR-07H	1000	1000	1000
CNR-10H	500	500	500
CNR-14H	500	500	500
CNR-18H	250	250	250
CNR-20H	250	250	250

Tape& Reel product packing

Series	A (mm)	Quantity (pcs/reel)
CNR-05H(180K~391K)-TRXX	43	2000
CNR-05H(431K~751K)-TRXX		1500
CNR-07H(180K~391K)-TRXX		2000
CNR-07H(431K~821K)-TRXX		1500
CNR-10H(180K~621K)-TRXX		1000
CNR-10H(681K~112K)-TRXX		800
CNR-14H(180K~391K)-TRXX	56	800
CNR-14(D431K~621K)-TRXX		700
CNR-14H(681K~112K)-TRXX		600

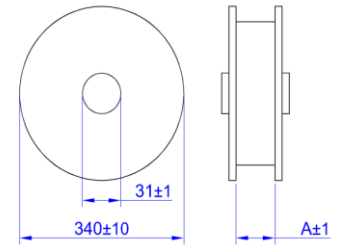

Flat Box product

Series	Quantity (pcs/box)
CNR-05H(180K~621K)-BTXX	1000
CNR-05H(681K~751K)-BTXX	800
CNR-07H(180K~621K)-BTXX	1000
CNR-07H(681K~821K)-BTXX	800
CNR-10H(180K~621K)-BTXX	1000
CNR-10H(681K~112K)-BTXX	800
CNR-14H(180K~621K)-BTXX	500
CNR-14H(681K~112K)-BTXX	400

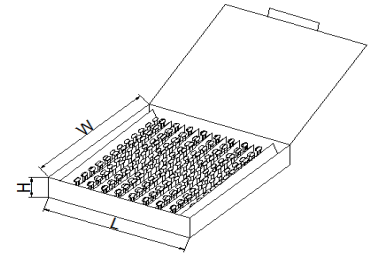

Series	L±5	W±5	H±5
CNR-05~07H	340	245	45
CNR-10~14H	340	245	50

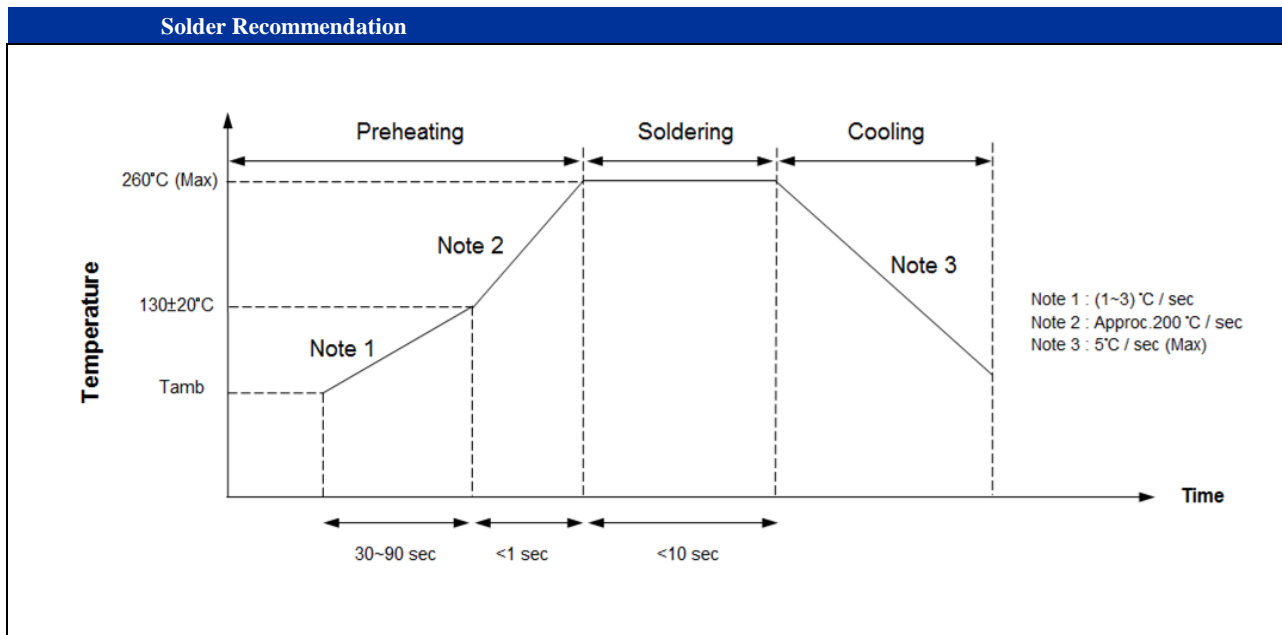

**Recommendation Reworking Conditions with Soldering Iron**

Item	Conditions
Temperature of soldering Iron-tip	360°C (Max)
Soldering Time	3 sec(Max)
Distance from Varistor	2mm(Min)

**RoHS Compliant Declaration**

We hereby declare that the components delivered to your company are compliant with RoHS Directive 2002/95/EC

**Storage Conditions of Products**

(I) Storage Conditions:

- 1.Storage Temperature: -10°C ~+40°C
- 2.Relative Humidity: ≤75%RH
- 3.Keep away from corrosive atmosphere and sunlight
- 4.Solvent Resistance: MIL-STD-202, Method 215F
- 5.Moisture Sensitivity: Level 1, J-STD-020

(II) Period of Storage: 1 year

**Explanation of Part Numbers**

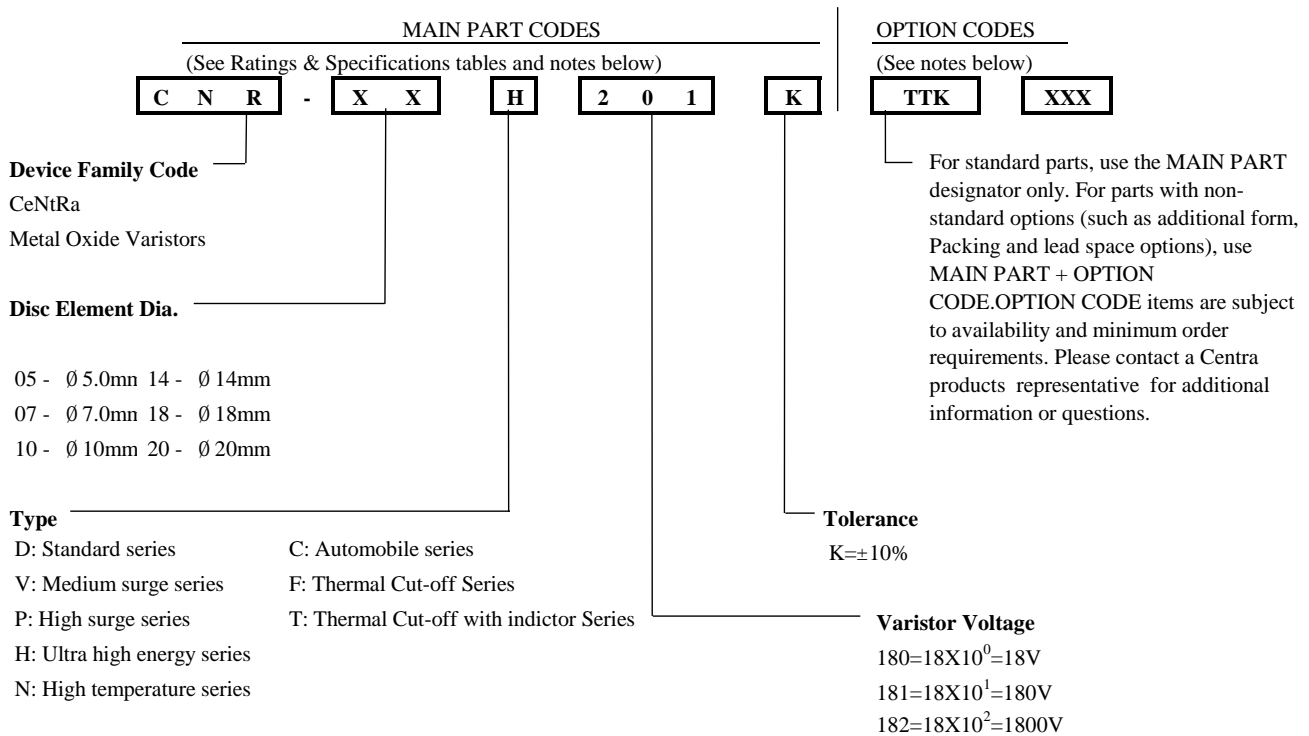

**Ordering Notes:**

**MAIN PART CODES**

Series + /Packaging/ Lead Style / Designators:

Ordering examples:

Straight Lead Bulk Pack (Standard)	Straight Lead (Short Cut) Bulk Pack	Straight Lead Tape & Reel Pack	Straight Lead Flat Box Pack
CNR-10H471K	CNR-10H471KTTSXXX	CNR-10H471KTRSX	CNR-10H471KBTSX

Outside Kink Lead Bulk Pack	Outside Kink Lead (Short Cut) Bulk Pack	Outside Kink Lead Tape & Reel Pack	Outside Kink Lead Flat Box Pack
CNR-10H471SOK	CNR-10H471KTKXXX	CNR-10H471KTRKX	CNR-10H471KBTKX

Inside Kink Lead Bulk Pack	Inside Kink Lead (Short Cut) Bulk Pack	Inside Kink Lead Tape & Reel Pack	Inside Kink Lead Flat Box Pack
CNR-10H471KSIK	CNR-10H471KTTIXXX	CNR-10H471KTRIX	CNR-10H471KBTIX

In Line Kink Lead Bulk Pack	In Line Kink Lead (Short Cut) Bulk Pack	In Line Kink Lead Tape & Reel Pack	In Line Kink Lead Flat Box Pack
CNR-10H471KSHK	CNR-10H471KTTHXXX	CNR-10H471KTRHX	CNR-10H471KBTHX

Option Code

+ XXX

Short Cut Lead Length 10mm±1.0mm
CNR-10H471KTTS10

Tape & Reel Pack Feed Hole Pitch 15mm±0.2mm
CNR-10H471KTRSA
CNR-10D471KTRSB

A: P<sub>0</sub> → 12.7mm±0.2mm  
B: P<sub>0</sub> → 15.0mm±0.2mm

CeNtRa H Series varistors are shipped standard in bulk pack with straight leads or Kink lead and lead spacing outlined in the Package Dimensions section of this data sheet. Contact your CeNtRa sales representative to discuss non-standard options.