



1. Scope:

This Specification covers the CNR GDT surge protector series for manufacturing gas tube arrests.

2. Part Number

Example: CG 3216 – XXX LF

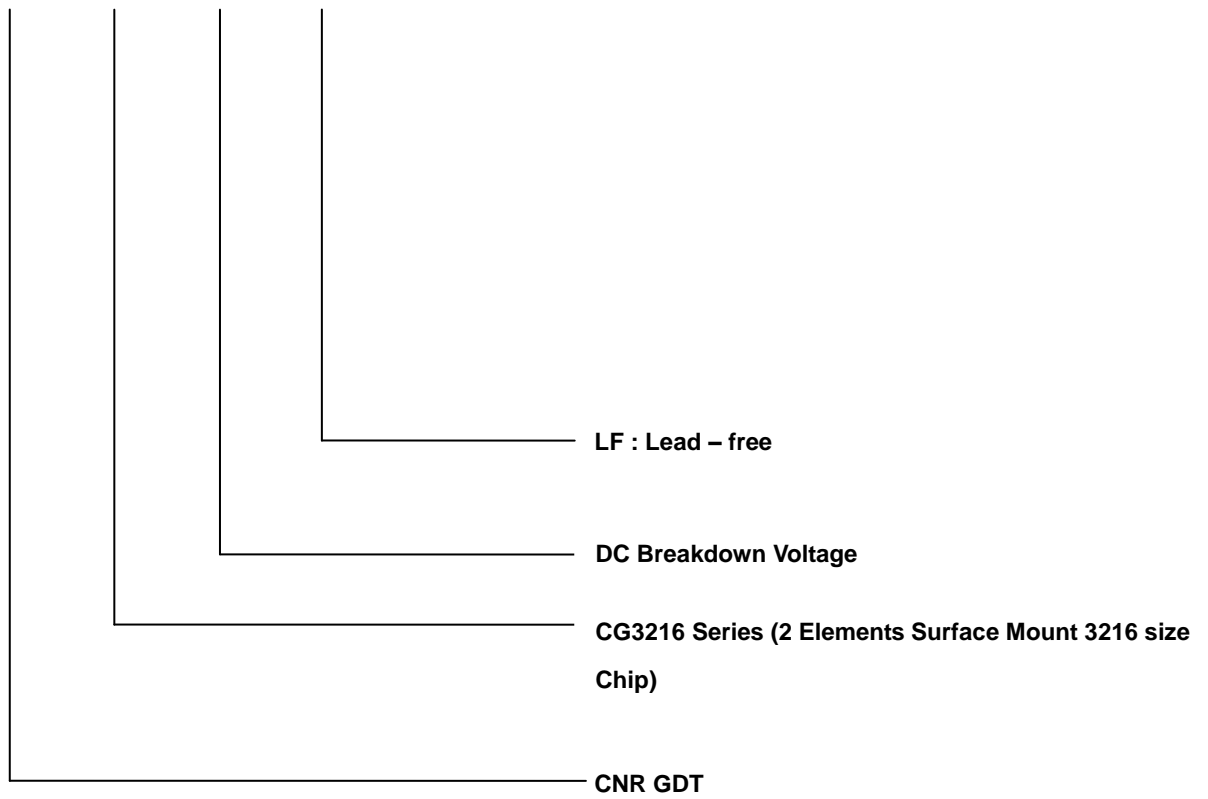



3. Production Dimensions (mm)

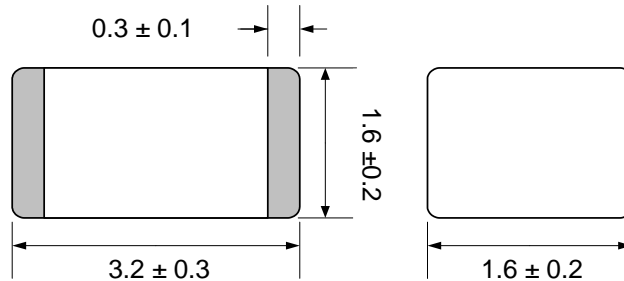

4. Electrical Specification

Model Name	DC Breakdown Voltage (*1)	Impulse Discharge Current (*2) (8/20 μ s)	Impulse spark-over Voltage	Alternating Discharge Current (50Hz, 1Sec, 10 times)	Impulse Life Test (8/20 μ s, 50A)	Insulation Resistance		Capacitance (*3) (1MHz)
	(V)	(A)	1kV/ μ s (V)	(A)	(times)	(G Ω)	V (DC)	(pF)
CG3216-150LF	150 \pm 20%	500	<700	0.5	300	>1	50	<1
CG3216-200LF	200 \pm 30%	500	<750	0.5	300	>1	100	<1
CG3216-400LF	400 \pm 30%	500	<950	0.5	300	>1	100	<1
CG3216-420LF	420 \pm 30%	500	<1000	0.5	300	>1	100	<1
CG3216-500LF	500 \pm 30%	500	<1150	0.5	300	>1	100	<1
CG3216-600LF	600 \pm 30%	500	<1300	0.5	300	>1	100	<1

Approvals – UL1449 4th Recognized, File E316325

1. The parameters of all tested by ITU-T K12.
2. Total Impulse discharge current 500A@8/20 μ s by IEC 61000-4-5, 10 shots.
3. The capacitance are tested by 1MHz @DC=0.5V.
4. The V-T waveform of DCBV and IPBV mus lie between the shades.

5. Packaging

Taping & Reel

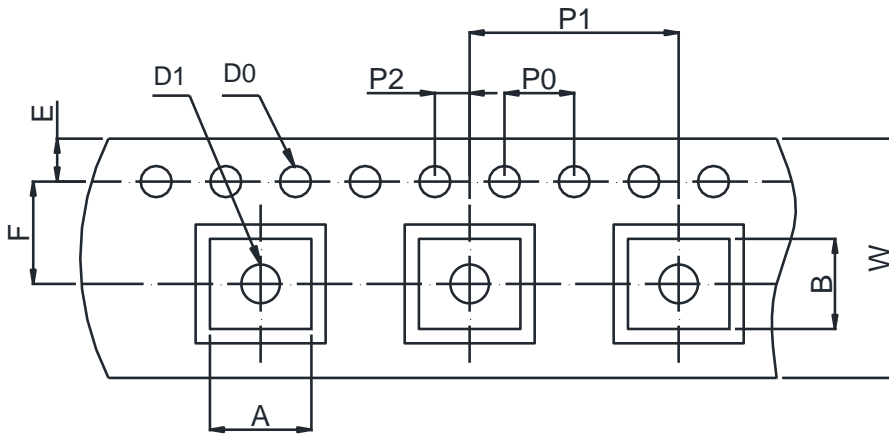

Item	Spec
A	1.9±0.1
B	3.5±0.1
D0	Φ1.5±0.1
D1	Φ1.1±0.1
E	1.75±0.1
F	5.5±0.1
P0	4.0±0.1
P1	8.0±0.1
P2	2.0±0.1
W	12±0.3

Unit - mm

Part Number	Component Package	Quantity
CG3216 series	3216 (1206)	2500

6. Storage Environment

1. Operate temperature: -40°C to 90°C
2. Storage temperature: -40°C to 115°C
3. Relative humidity: ≤75%RH
4. Do not store in an environment with corrosive gas or direct sunlight.

- Storage period: 1 year

7. RECOMMENDED SOLDERING PAD

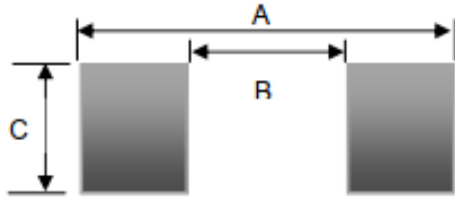

REF	mm
A	4.5
B	2.0
C	1.8

8. REFLOW PROFILE

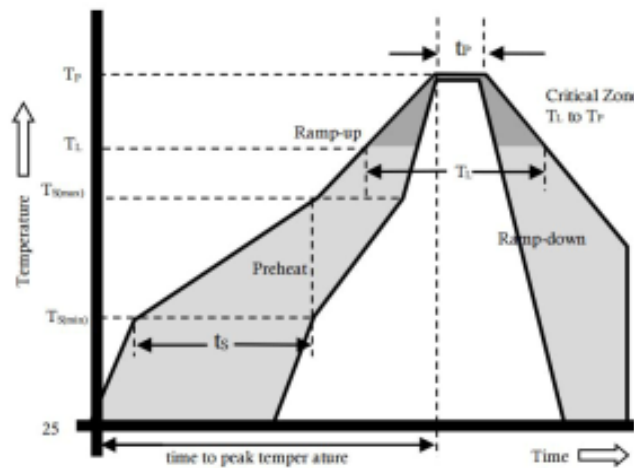

Reflow Condition	Pb-Free assembly
Pre Heat : Temperature Min	150°C
Temperature Max	200°C
Time(min to max)	60-180 seconds
Average ramp up rate(Liquids)Tamp(TL) to peak	3°C/second max
Ts(max) to TL-Ramp-up Rate	3°C/second max
Reflow -Temperature (TL) (Liquids)	217°C
Reflow -Temperature (TL)	60-150 seconds
Peak Temperature (Tp)	260+0/-5°C
Time within 5°C of actual peak : Temperature (tp)	~10 seconds
Ramp-down Rate	6°C/second max.
Time 25°C to peak Temperature (Tp)	8 minutes max.
Do not exceed	260°C



9. Electrical Terms and Definitions

Item	Test Condition / Description	Requirement
DC Breakdown Voltage	The voltage measured at a rise time of 100v/s.	To meet the specified value
Maximum Impulse Breakdown Voltage	The maximum breakdown voltage at rise times of 100v/us and 1000v/us.	
Maximum Impulse Discharge Current	The maximum current applying a waveform of 8/20us that can be applied across the terminals of the gas tube without causing the gas tube to change more than ±25% from its initial measured DC breakdown voltage. Dwell time between pulses is 3 minutes.	
Impulse Life	The minimum number of impulses of a specified waveform and peak current which a gas tube will conduct without causing the gas tube to change more than ±25% from its initial measured DC breakdown voltage. Dwell time between pulses is 1-2 minutes.	
Alternating Discharge Current	Rated RMS value of AC current at 50Hz, 1 sec. 10 times. Intervals: 3min. DC breakdown voltage may not change more than ±25% from its initial measured DC breakdown voltage. IR > 10 ⁸ ohms (-20%, +30% for 70 – 90V).	
Capacitance	The capacitance of a gas tube shall be measured each terminal to each other terminal. Test frequency: 1MHz In measurements involving 3-electrode gas tubes, the terminal not being tested shall be connected to a ground plane.	